

# TLP108

Isolated bus drivers  
 High speed line receivers  
 Microprocessor system interfaces

The Toshiba TLP108 consists of a GaAlAs light emitting diode optically coupled to a high-gain, high-speed photodetector.

The TLP108 is housed in a 6-pin MFSOP.

With a totem-pole output, the TLP108 is capable of both sinking and sourcing current.

The TLP108 has an internal Faraday shield, which provides a guaranteed common-mode transient immunity of  $\pm 10$  kV/ $\mu$ s.

The TLP108 has an inverting output. A noninverting-output version, the TLP105, is also available.

- Inverter logic type (totem-pole output)
- Guaranteed Performance Over temperature: -40 to 100°C
- Power Supply Voltage: 4.5 to 20 V
- Input Threshold Current:  $I_{FHL} = 1.6$  mA (max)
- Switching Time ( $t_{pLH}/t_{pHL}$ ): 250 ns (max)
- Common mode transient immunity:  $\pm 10$  kV/ $\mu$ s
- Isolation Voltage: 3750 Vrms

**Truth Table**

Input	LED	Tr1	Tr2	Output
H	ON	OFF	ON	L
L	OFF	ON	OFF	H

Unit in mm

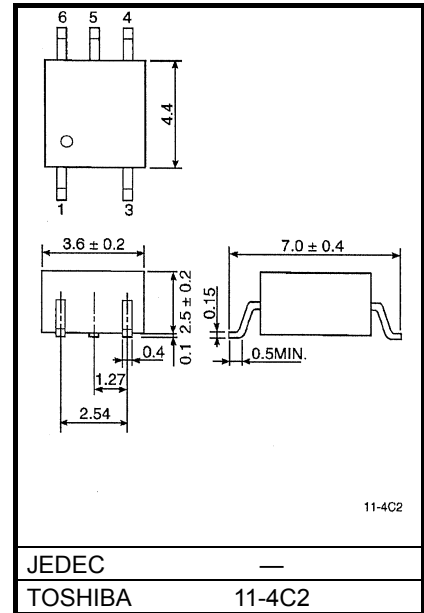

Weight: 0.09 g

**Pin Configuration (top View)**

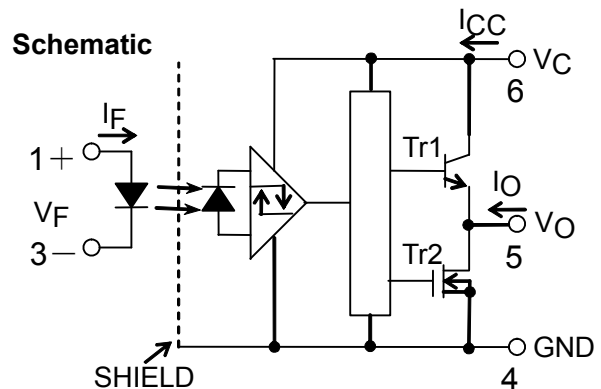
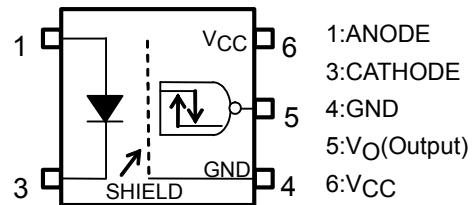

**0.1  $\mu$ F bypass capacitor must be connected between pin 6 and 4.**

## Recommended Operating Conditions

CHARACTERISTIC	SYMBOL	MIN	TYP.	MAX	UNIT
Input Current , ON	$I_{F(ON)}$	2	—	10	mA
Input Voltage , OFF	$V_{F(OFF)}$	0	—	0.8	V
Supply Voltage*	$V_{CC}$	4.5	—	20	V
Operating Temperature	$T_{opr}$	-40	—	100	°C
Fan-out (TTL Load)	N	—	—	4	—

\* This item denotes operating range, not meaning of recommended operating conditions.

Note: Recommended operating conditions are given as a design guideline to obtain expected performance of the device. Additionally, each item is an independent guideline respectively. In developing designs using this product, please confirm specified characteristics shown in this document.

## Absolute Maximum Ratings (Ta = 25°C)

CHARACTERISTIC		SYMBOL	RATING	UNIT
LED	Forward Current	$I_F$	20	mA
	Peak Transient Forward Current (Note1)	$I_{FPT}$	1	A
	Reverse Voltage	$V_R$	5	V
DETECTOR	Output Current 1 (Ta ≤ 25°C)	$I_{O1}$	25/-15	mA
	Output Current 2 (Ta ≤ 100°C)	$I_{O2}$	5/-5	mA
	Peak Output Current (Note2)	$I_{OP}$	50/-50	mA
	Output Voltage	$V_O$	-0.5 to 20	V
	Supply Voltage	$V_{CC}$	-0.5 to 20	V
Operating Temperature Range		$T_{opr}$	-40 to 100	°C
Storage Temperature Range		$T_{stg}$	-55 to 125	°C
Lead Solder Temperature (10s)		$T_{sol}$	260	°C
Isolation Voltage (AC, 1min., R.H. ≤ 60%, Ta=25°C) (Note3)		$BV_s$	3750	$V_{rms}$

Note: Using continuously under heavy loads (e.g. the application of high temperature/current/voltage and the significant change in temperature, etc.) may cause this product to decrease in the reliability significantly even if the operating conditions (i.e. operating temperature/current/voltage, etc.) are within the absolute maximum ratings.

Please design the appropriate reliability upon reviewing the Toshiba Semiconductor Reliability Handbook ("Handling Precautions"/"Derating Concept and Methods") and individual reliability data (i.e. reliability test report and estimated failure rate, etc).

Note 1: Pulse width ≤ 1μs, 300pps.

Note 2: Pulse width ≤ 5μs, duty cycle ≤ 0.025

Note 3: Device considered a two terminal device: pins 1 and 3 shorted together and pins 4, 5 and 6 shorted together.

**Electrical Characteristics**

(Unless otherwise specified, Ta = -40 to 100°C, VCC = 4.5 to 20 V)

CHARACTERISTIC	SYMBOL	TEST CIRCUIT	CONDITION	MIN	TYP.	MAX	UNIT	
Input Forward Voltage	V <sub>F</sub>	—	I <sub>F</sub> =10 mA, Ta=25°C	1.45	1.57	1.75	V	
Temperature Coefficient of Forward Voltage	ΔV <sub>F</sub> /ΔTa	—	I <sub>F</sub> =10 mA	—	-2.0	—	mV/°C	
Input Reverse Current	I <sub>R</sub>	—	V <sub>R</sub> =5 V, Ta=25°C	—	—	10	μA	
Input Capacitance	C <sub>T</sub>	—	V=0, f=1 MHz, Ta=25°C	—	100	—	pF	
Logic Low Output Voltage	V <sub>OL</sub>	1	I <sub>OL</sub> =3.5 mA, I <sub>F</sub> =5 mA	—	0.2	0.6	V	
Logic High Output Voltage	V <sub>OH</sub>	2	I <sub>OH</sub> =-2.6 mA, V <sub>F</sub> =0.8 V	V <sub>CC</sub> =4.5 V	2.7	4.0	—	V
				V <sub>CC</sub> =20 V	17.4	19.0	—	
Logic Low Supply Current	I <sub>CCL</sub>	3	I <sub>F</sub> =5 mA	V <sub>CC</sub> =20 V	—	—	3.0	mA
				V <sub>CC</sub> =5.5 V	—	—	3.0	
Logic High Supply Current	I <sub>CCH</sub>	4	V <sub>F</sub> =0 V	V <sub>CC</sub> =20 V	—	—	3.0	mA
				V <sub>CC</sub> =5.5 V	—	—	3.0	
Logic Low Short Circuit Output Current (Note4)	I <sub>OSL</sub>	5	I <sub>F</sub> =5 mA, V <sub>O</sub> =GND	V <sub>CC</sub> =V <sub>O</sub> =5.5 V	15	80	—	mA
				V <sub>CC</sub> =V <sub>O</sub> =20 V	20	90	—	
Logic High Short Circuit Output Current (Note4)	I <sub>OSH</sub>	6	V <sub>F</sub> =0 V	V <sub>CC</sub> =5.5 V	-5	-15	—	mA
				V <sub>CC</sub> =20 V	-10	-20	—	
Input Current Logic Low Output	I <sub>FHL</sub>	—	I <sub>O</sub> =3.5 mA, V <sub>O</sub> <0.4 V	—	0.4	1.6	mA	
Input Voltage Logic High Output	V <sub>FLH</sub>	—	I <sub>O</sub> =-2.6 mA, V <sub>O</sub> >2.4 V	0.8	—	—	V	
Input Current Hysteresis	I <sub>HYS</sub>	—	V <sub>CC</sub> =5 V	—	0.05	—	mA	

\*All typical values are at Ta=25°C

Note 4: Duration of output short circuit time should not exceed 10 ms.

**Isolation Characteristics (Ta = 25°C)**

Characteristic	Symbol	Test Condition	Min.	Typ.	Max.	Unit
Capacitance input to output	C <sub>S</sub>	V <sub>S</sub> = 0, f = 1 MHz (Note 3)	—	0.8	—	pF
Isolation resistance	R <sub>S</sub>	R.H. ≤ 60%, V <sub>S</sub> = 500 V (Note 3)	1×10 <sup>12</sup>	10 <sup>14</sup>	—	Ω
Isolation voltage	BV <sub>S</sub>	AC, 1 minute	3750	—	—	V <sub>rms</sub>
		AC, 1 second, in oil	—	10000	—	V <sub>dc</sub>
		DC, 1 minute, in oil	—	10000	—	

Note 5: A ceramic capacitor (0.1μA) should be connected from pin 6 to pin 4 to stabilize the operation of the high gain linear amplifier. Failure to provide the bypassing may impair the switching property. The total lead length between capacitor and coupler should not exceed 1 cm.

**Switching Characteristics**

(Unless otherwise specified,  $T_a = -40$  to  $100^\circ\text{C}$ ,  $V_{CC} = 4.5$  to  $20\text{ V}$ )

CHARACTERISTIC	SYMBOL	TEST CIRCUIT	CONDITION	MIN.	TYP.	MAX.	UNIT
Propagation Delay Time to Logic High output	$t_{pLH}$	7, 8	$I_F=3\rightarrow 0\text{mA}$	30	150	250	ns
Propagation Delay Time to Logic Low output	$t_{pHL}$		$I_F=0\rightarrow 3\text{mA}$	30	150	250	ns
Switching Time Dispersion between ON and OFF	$ t_{pHL}-t_{pLH} $		—	—	—	220	ns
Rise Time (10 – 90 %)	$t_r$		$I_F=3\rightarrow 0\text{mA}$ , $V_{CC}=5\text{V}$	—	30	75	ns
Fall Time (90 – 10 %)	$t_f$		$I_F=0\rightarrow 3\text{mA}$ , $V_{CC}=5\text{V}$	—	30	75	ns
Common Mode transient Immunity at High Level Output	$CM_H$	9	$V_{CM}=1000\text{V}_{p-p}$ , $I_F=0\text{mA}$ , $V_{CC}=20\text{V}$ , $T_a=25^\circ\text{C}$	-10000	—	—	$\text{V}/\mu\text{s}$
Common Mode transient Immunity at Low Level Output	$CM_L$		$V_{CM}=1000\text{V}_{p-p}$ , $I_F=5\text{mA}$ , $V_{CC}=20\text{V}$ , $T_a=25^\circ\text{C}$	10000	—	—	$\text{V}/\mu\text{s}$

\*All typical values are at  $T_a=25^\circ\text{C}$

**TEST CIRCUIT 1 :  $V_{OL}$**

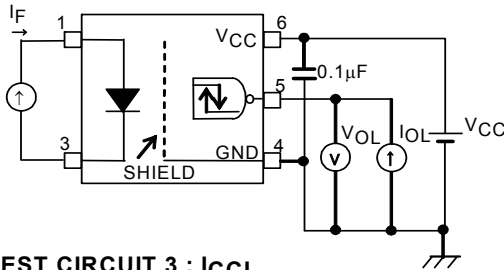

**TEST CIRCUIT 2 :  $V_{OH}$**

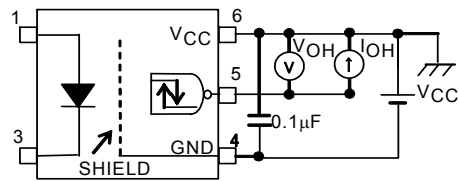

**TEST CIRCUIT 3 :  $I_{CCL}$**

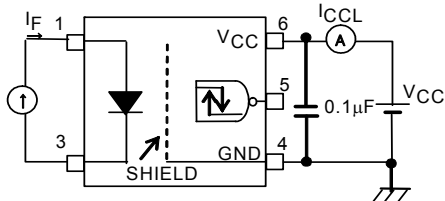

**TEST CIRCUIT 4 :  $I_{CCH}$**

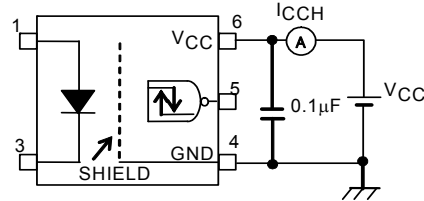

**TEST CIRCUIT 5 :  $I_{OSL}$**

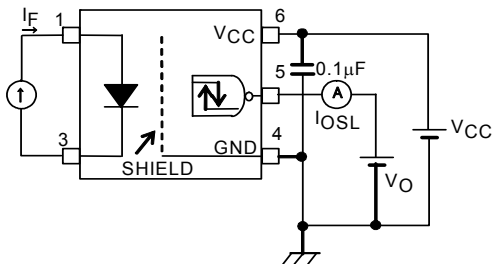

**TEST CIRCUIT 6 :  $I_{OSH}$**

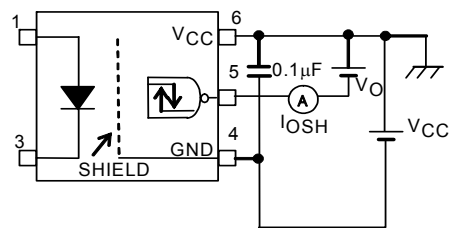

**TEST CIRCUIT 7: Switching Time Test Circuit**

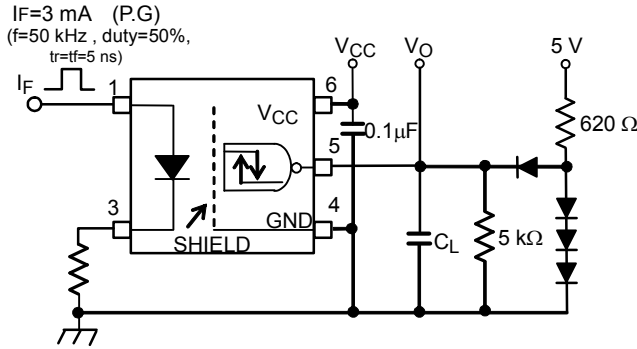

$C_L$  is approximately 15 pF which includes probe and stray wiring capacitance.  
 P.G.: Pulse generator

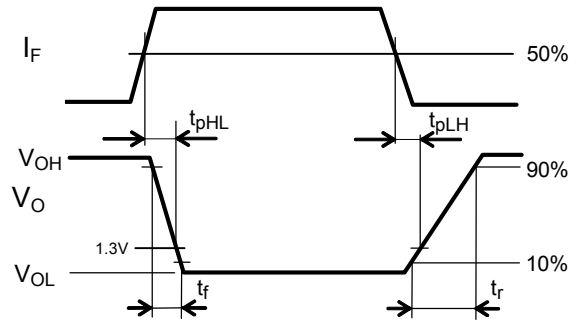

**TEST CIRCUIT 8: Switching Time Test Circuit**

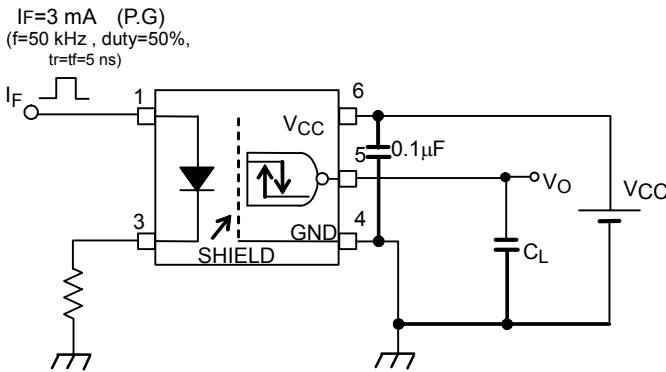

$C_L$  is approximately 15 pF which includes probe and stray wiring capacitance.  
 P.G.: Pulse generator

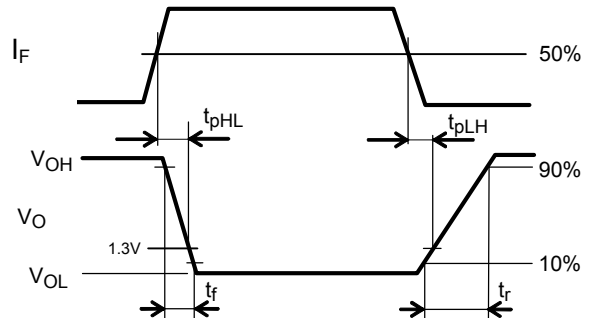

**TEST CIRCUIT 9: Common Mode Transient Immunity Test Circuit**

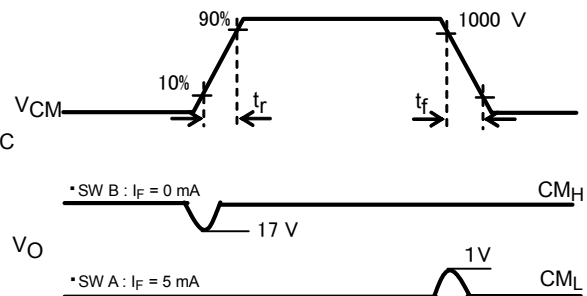
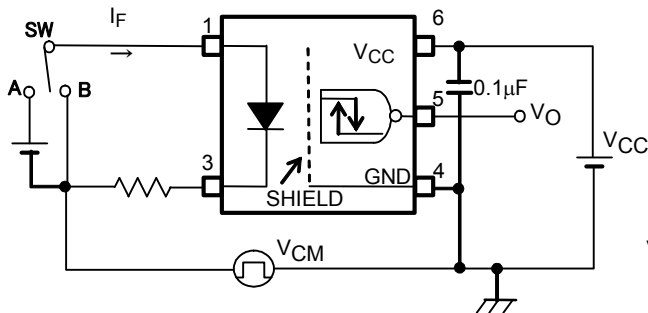

$$CM_H = \frac{800(V)}{t_f(\mu s)} \quad CM_L = \frac{800(V)}{t_r(\mu s)}$$

**RESTRICTIONS ON PRODUCT USE**

20070701-EN GENERAL

- The information contained herein is subject to change without notice.
- TOSHIBA is continually working to improve the quality and reliability of its products. Nevertheless, semiconductor devices in general can malfunction or fail due to their inherent electrical sensitivity and vulnerability to physical stress. It is the responsibility of the buyer, when utilizing TOSHIBA products, to comply with the standards of safety in making a safe design for the entire system, and to avoid situations in which a malfunction or failure of such TOSHIBA products could cause loss of human life, bodily injury or damage to property.  
In developing your designs, please ensure that TOSHIBA products are used within specified operating ranges as set forth in the most recent TOSHIBA products specifications. Also, please keep in mind the precautions and conditions set forth in the "Handling Guide for Semiconductor Devices," or "TOSHIBA Semiconductor Reliability Handbook" etc.
- The TOSHIBA products listed in this document are intended for usage in general electronics applications (computer, personal equipment, office equipment, measuring equipment, industrial robotics, domestic appliances, etc.). These TOSHIBA products are neither intended nor warranted for usage in equipment that requires extraordinarily high quality and/or reliability or a malfunction or failure of which may cause loss of human life or bodily injury ("Unintended Usage"). Unintended Usage include atomic energy control instruments, airplane or spaceship instruments, transportation instruments, traffic signal instruments, combustion control instruments, medical instruments, all types of safety devices, etc.. Unintended Usage of TOSHIBA products listed in this document shall be made at the customer's own risk.
- The products described in this document shall not be used or embedded to any downstream products of which manufacture, use and/or sale are prohibited under any applicable laws and regulations.
- GaAs(Gallium Arsenide) is used in this product. The dust or vapor is harmful to the human body. Do not break, cut, crush or dissolve chemically.
- Please contact your sales representative for product-by-product details in this document regarding RoHS compatibility. Please use these products in this document in compliance with all applicable laws and regulations that regulate the inclusion or use of controlled substances. Toshiba assumes no liability for damage or losses occurring as a result of noncompliance with applicable laws and regulations.