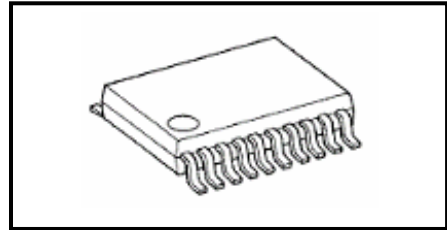

**Preliminary**

Toshiba Bi-CD Integrated Circuit Silicon Monolithic

**T B 6 5 9 3 F N G****Driver IC for DC motor**

TB6593FNG is a driver IC for DC motor with output transistor in LD MOS structure with low ON-resistor. Two input signals, IN1 and IN2, can choose one of four modes such as CW, CCW, short brake, and stop mode.

**Features**

- Power supply voltage :  $V_M=15V$  ( Max. )
- Output current :  $I_{out}=1.2A(ave) / 3.2A$  (peak)
- Output low ON resistor : 0.35 ((typ. @ $V_M$  5V)
- Standby (Power save)system
- CW/CCW/short brake/stop function modes
- Built-in thermal shutdown circuit and low voltage detecting circuit
- Small faced package ( SSOP20:0.65mm pitch )
- Response to Pb free packaging

Weight

SSOP20-P-225-0.65: 0.09g (Typ.)

The TB6593FNG is a Pb-free product.

The following conditions apply to solderability:

\*Solderability

1. Use of Sn-63Pb solder bath
  - \*solder bath temperature = 230°C
  - \*dipping time = 5 seconds
  - \*number of times = once
  - \*use of R-type flux
2. Use of Sn-3.0Ag-0.5Cu solder bath
  - \*solder bath temperature = 245°C
  - \*dipping time = 5 seconds
  - \*the number of times = once
  - \*use of R-type flux

\* This product has a MOS structure and is sensitive to electrostatic discharge. When handling this product, ensure that the environment is protected against electrostatic discharge by using an earth strap, a conductive mat and an ionizer. Ensure also that the ambient temperature and relative humidity are maintained at reasonable levels.

## Block Diagram

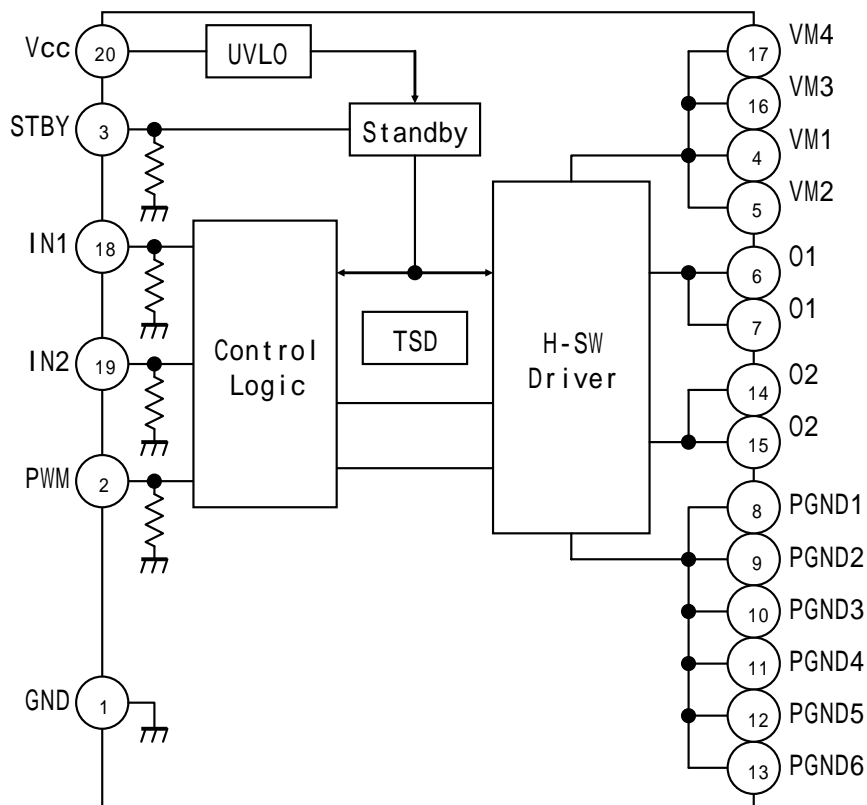

## Pin Functions

Pin NO.	Symbol	Characteristics	Remarks
1	GND	Small signal GND	
2	PWM	PWM signal input	"H"=Active / 200k pull-down at internal
3	STBY	Standby signal input	"L"=standby / 200k pull-down at internal
4	VM1	VM supply	VM=2.5V~13.5V
5	VM2		
6	O1	Output1	
7	O1		
8	PGND1	Power GND	
9	PGND2		
10	PGND3		
11	PGND4		
12	PGND5		
13	PGND6		
14	O2	Output2	
15	O2		
16	VM3	VM supply	VM=2.5V~13.5V
17	VM4		
18	IN1	Control signal nput1	200k pull-down at internal
19	IN2	Control signal input2	
20	Vcc	Small signal supply	Vcc=2.7V ~ 5.5V

( Pin alignments are temporary. )

## Maximum Ratings (Ta = 25°C)

Characteristics	Symbol	Rating	Unit	Remarks
Supply voltage	VM	15	V	
	Vcc	6		
Input voltage	VIN	-0.2 ~ 6	V	IN1,IN2,STBY,PWM pins
Output voltage	Vout	15	V	O1,O2 pins
Output current	Iout	1.2	A	
	Iout (peak)	3.2		tw=10ms, Superimposed pulse, Duty is 30% or less.
Power dissipation	PD	0.96	W	50×50×1.6mm When it is packaged to the board made of glass-epoxy (Cu40%).
Operating temperature	Topr	-20 ~ 85		
Storage temperature	Tstg	-55 ~ 150		

## Operating Range (Ta = -20 to 85°C)

Characteristics	Symbol	Min	Typ.	Max	Unit
Supply voltage	Vcc	2.7	3	5.5	V
	VM	2.5	5	13.5	V
Output current (H-SW)	Iout	---	---	1.0	A
Switching frequency	fPWM	---	---	100	kHz

## H-SW Control Function

Input				Output		
IN1	IN2	PWM	STBY	OUT1	OUT2	Mode
H	H	H	H	L	L	Short brake
L	H	H	H	L	H	CCW
		L	H	L	L	Short brake
H	L	H	H	H	L	CW
		L	H	L	L	Short brake
L	L	H	H	OFF (High impedance)		Stop
H / L	H / L	H	L	OFF (High impedance)		Standby

## H-SW Operating Description

•To prevent penetrating current, dead time  $t_2$  and  $t_4$  (300ns: Designed value) is provided in switching to each mode in the IC.

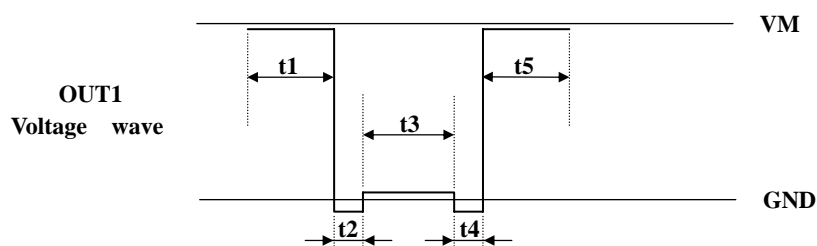
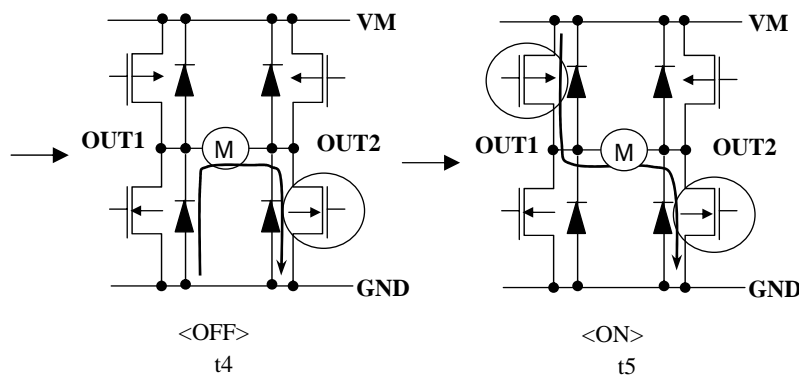
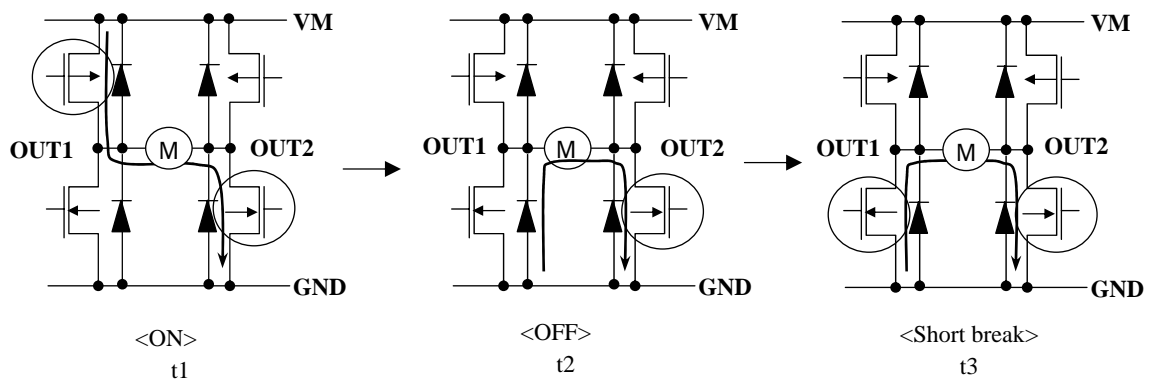

## Electrical Characteristics (unless otherwise specified, $V_{CC} = 3\text{ V}$ , $V_M = 4.5\text{ V}$ , $T_a = 25^\circ\text{C}$ )

Characteristics	Symbol	Test Condition	Min	Typ.	Max	Unit
Supply current	$I_{cc}$	STBY= $V_{CC}$	---	0.9	1.2	mA
	$I_{cc}(\text{STB})$	STBY=0V	---	---	1	$\mu\text{A}$
	$I_M(\text{STB})$		---	---	1	
Control input voltage	$V_{IH}$		2	---	$V_{CC}+0.2$	V
	$V_{IL}$		-0.2	---	0.8	
Control input current	$I_{IH}$	$V_{IN}=3\text{ V}$	5	15	25	$\mu\text{A}$
	$I_{IL}$	$V_{IN}=0\text{ V}$	---	---	1	
Standby input voltage	$V_{IH}(\text{STB})$		2	---	$V_{CC}+0.2$	V
	$V_{IL}(\text{STB})$		-0.2	---	0.8	
Standby input current	$I_{IH}(\text{STB})$	$V_{IN}=3\text{ V}$	5	15	25	$\mu\text{A}$
	$I_{IL}(\text{STB})$	$V_{IN}=0\text{ V}$	---	---	1	
Output saturating voltage	$V_{sat}(U+L)$	$I_o=1\text{ A}$	---	(0.35)	(0.5)	V
Output leakage current	$I_L(U)$	$V_M=V_{out}=15\text{ V}$	---	---	1	$\mu\text{A}$
	$I_L(L)$	$V_M=15\text{ V}, V_{out}=0\text{ V}$	-1	---	---	
Regenerative diode VF	$V_F(U)$	$I_F=1\text{ A}$	---	1	(1.1)	V
	$V_F(L)$		---	1	(1.1)	
Low voltage detecting voltage	UVLD	(Designed value)	---	2.0	---	V
Recovering voltage	UVLC		---	2.2	---	
Thermal shutdown circuit operating temperature	TSD	(Designed value)	---	170	---	
Thermal shutdown hysteresis	$\Delta\text{TSD}$		---	20	---	



**Package Dimensions**

SSOP20-P-225-0.65

Unit: mm

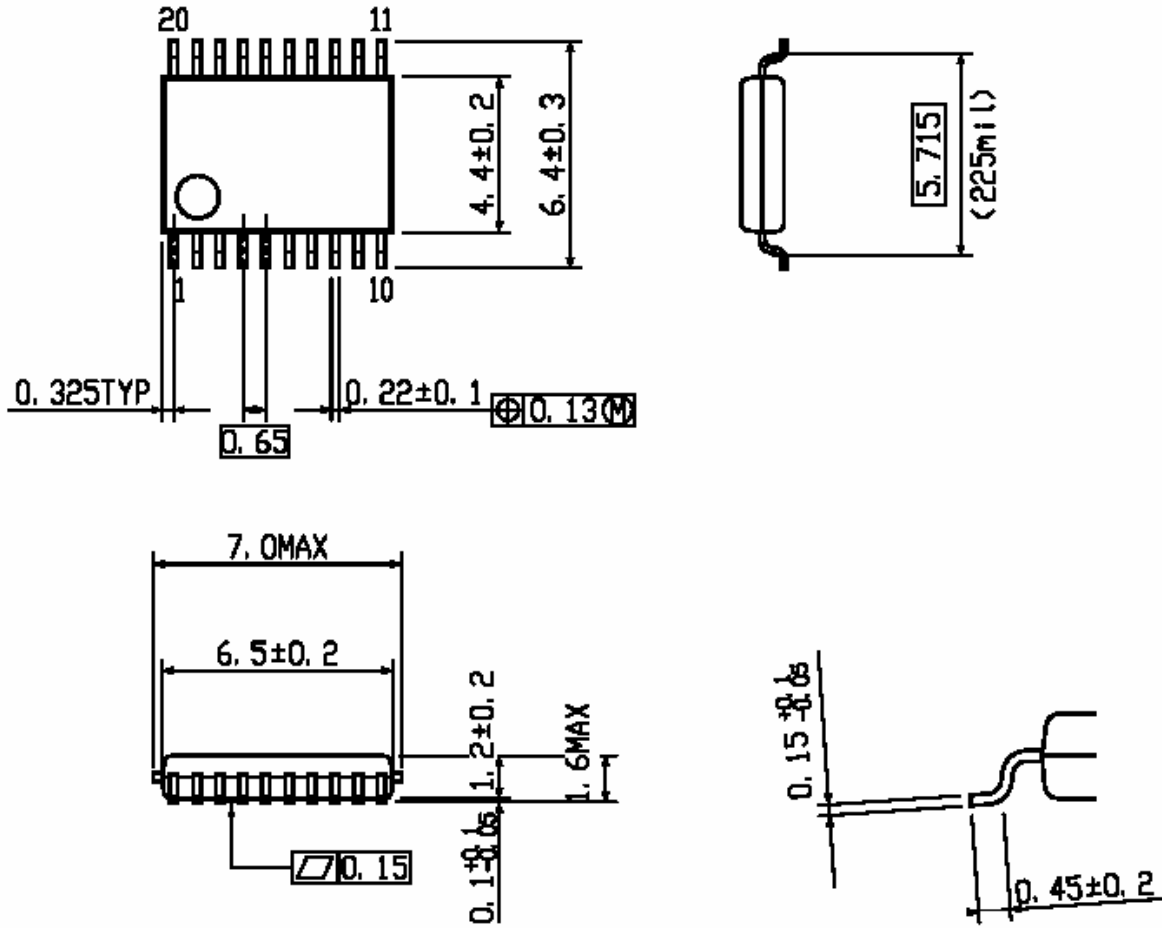

Weight: 0.09 g (Typ.)

## Notes on Contents

### 1. Block Diagrams

Some of the functional blocks, circuits, or constants in the block diagram may be omitted or simplified for explanatory purposes.

### 2. Equivalent Circuits

The equivalent circuit diagrams may be simplified or some parts of them may be omitted for explanatory purposes.

### 3. Timing Charts

Timing charts may be simplified for explanatory purposes.

### 4. Maximum Ratings

The absolute maximum ratings of a semiconductor device are a set of specified parameter values which must not be exceeded during operation, even for an instant.

If any of these ratings are exceeded during operation, the device electrical characteristics may be irreparably altered and the reliability and lifetime of the device can no longer be guaranteed.

Moreover, these operations with exceeded ratings may cause breakdown, damage and/or degradation to other equipment. Applications using the device should be designed so that each maximum rating will never be exceeded in any operating conditions.

Before using, creating and/or producing designs, refer to and comply with the precautions and conditions set forth in this document.

### 5. Application Circuits

The application circuits shown in this document are provided for reference purposes only. Thorough evaluation is required, especially at the mass production design stage.

Toshiba does not grant any license to any industrial property rights by providing these examples of application circuits.

### 6. Test Circuits

Components in the test circuits are used only to obtain and confirm the device characteristics. These components and circuits are not guaranteed to prevent malfunction or failure from occurring in the application equipment.

## About the handling of ICs

Install the product correctly to avoid breakdown, damage and/or degradation to the product or equipment.

## About overcurrent protection and heat protection circuits

These protection functions are intended to guard against certain output short circuits or other abnormal conditions with only temporary effect, and are not guaranteed to prevent the IC from being damaged.

- These protection features may not be effective if the product is operated outside the guaranteed operating ranges, and some output short circuits may result in the IC being damaged.

The overcurrent protection feature is only intended to protect the IC from a temporary short circuit.

Short circuits of longer duration may damage the IC through undue stress. The systems must be configured so that any overcurrent condition will be eliminated as soon as possible.

## Counter-electromotive force

When the motor reverses or stops, counter-electromotive force in the motor may influence the current to flow to the power source. If the power source lacks sink capability, the IC power and output pins may exceed the rating. The counter-electromotive force of the motor varies depending on the conditions of use and the features of the motor.

Therefore ensure that there is no damage to the IC or problem in operation, and no error in or damage to peripheral circuits resulting from counter-electromotive force.

**RESTRICTIONS ON PRODUCT USE**

030619EBA

- The information contained herein is subject to change without notice.
- The information contained herein is presented only as a guide for the applications of our products. No responsibility is assumed by TOSHIBA for any infringements of patents or other rights of the third parties which may result from its use. No license is granted by implication or otherwise under any patent or patent rights of TOSHIBA or others.
- TOSHIBA is continually working to improve the quality and reliability of its products. Nevertheless, semiconductor devices in general can malfunction or fail due to their inherent electrical sensitivity and vulnerability to physical stress. It is the responsibility of the buyer, when utilizing TOSHIBA products, to comply with the standards of safety in making a safe design for the entire system, and to avoid situations in which a malfunction or failure of such TOSHIBA products could cause loss of human life, bodily injury or damage to property.  
In developing your designs, please ensure that TOSHIBA products are used within specified operating ranges as set forth in the most recent TOSHIBA products specifications. Also, please keep in mind the precautions and conditions set forth in the "Handling Guide for Semiconductor Devices," or "TOSHIBA Semiconductor Reliability Handbook" etc..
- The TOSHIBA products listed in this document are intended for usage in general electronics applications (computer, personal equipment, office equipment, measuring equipment, industrial robotics, domestic appliances, etc.). These TOSHIBA products are neither intended nor warranted for usage in equipment that requires extraordinarily high quality and/or reliability or a malfunction or failure of which may cause loss of human life or bodily injury ("Unintended Usage"). Unintended Usage include atomic energy control instruments, airplane or spaceship instruments, transportation instruments, traffic signal instruments, combustion control instruments, medical instruments, all types of safety devices, etc.. Unintended Usage of TOSHIBA products listed in this document shall be made at the customer's own risk.
- The products described in this document are subject to the foreign exchange and foreign trade laws.
- TOSHIBA products should not be embedded to the downstream products which are prohibited to be produced and sold, under any law and regulations.