

# TB6585FG

## 3-Phase Sine-Wave PWM Driver for BLDC Motors

### Features

- Sine-wave PWM drive
- Triangular-wave generator
- Hall amplifier
- Lead angle control
- Current limit control input ( $V_{RS} = 0.5 \text{ V (typ.)}$ )
- Rotation pulse output (3 pulse/electrical degree 360°C)
- Operating supply voltage range:  $V_M = 4.5 \text{ to } 42 \text{ V}$
- Reference supply output:  $V_{refout} = 4.4 \text{ V (typ.)}$ , 20 mA (max)
- Output current:  $I_{OUT} = 1.8 \text{ A (max)}$ , 1.2 A (typ.)
- Output On-resistance:  $R_{on}$  (P-channel and N-channel sum) = 0.7  $\Omega$  (typ.)

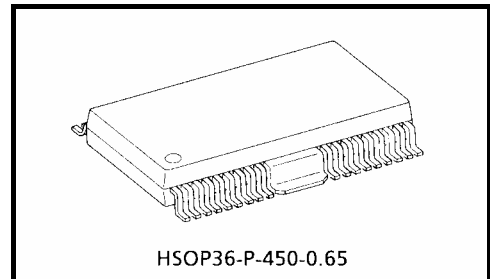

Weight: 0.79 g (typ.)

About solderability, following conditions were confirmed

- Solderability
  - (1) Use of Sn-37Pb solder Bath
    - solder bath temperature = 230°C
    - dipping time = 5 seconds
    - the number of times = once
    - use of R-type flux
  - (2) Use of Sn-3.0Ag-0.5Cu solder Bath
    - solder bath temperature = 245°C
    - dipping time = 5 seconds
    - the number of times = once
    - use of R-type flux

## Pin Assignment

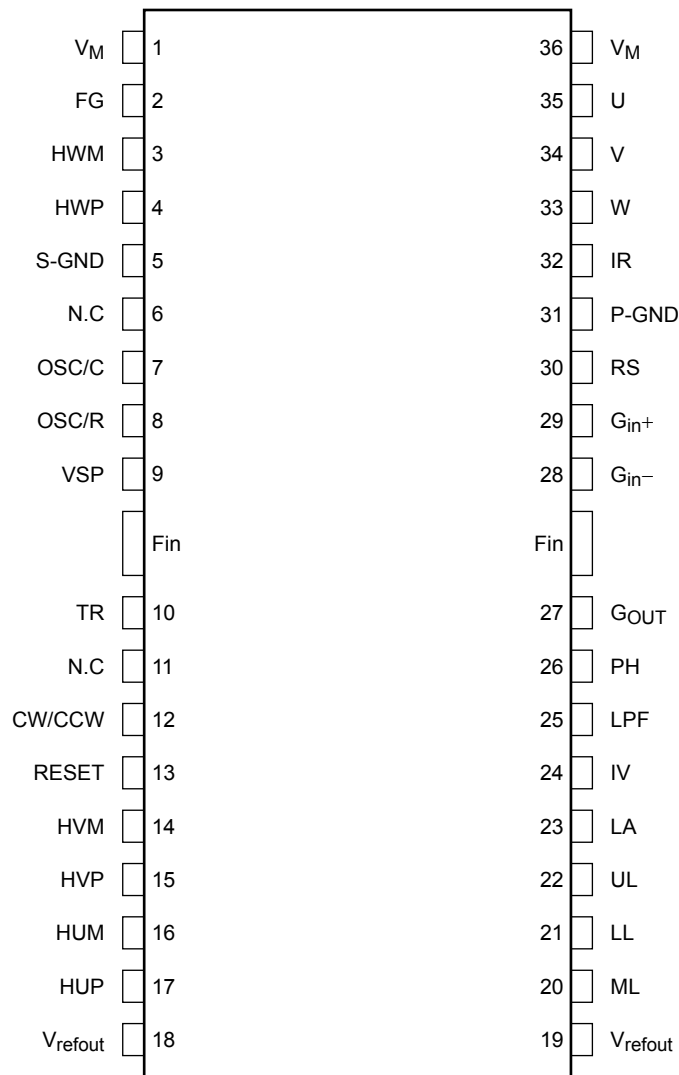

Note: Pins 1 and 36 and pins 18 and 19 are respectively connected together on the frame inside the IC.  
 The NC pin can be used as a jumper. The fin and the package bottom are electrically connected. To stabilize the chip, the Fin pins should be connected to S-GND and P-GND at a location as close to the TB6585FG as possible.

## Pin Description

Pin No.	Symbol	Description
1, 36	V <sub>M</sub>	Motor power supply pin (V <sub>M</sub> = 4.5 to 42 V)
2	FG	Rotation speed output pin (3 pulses per electrical degree)
3	HWM	W-phase Hall-signal input (-)
4	HWP	W-phase Hall signal input (+)
5	S-GND	Signal ground
6	N.C	No-connect
7	OSC/C	Connection pin for a capacitor to control PWM oscillation
8	OSC/R	Connection pin for a resistor to control PWM oscillation
9	VSP	Speed control input
10	TR	Time setting pin for the anti-lock system
11	N.C	No-connect
12	CW/CCW	Rotation direction select input
13	RESET	Reset pin for disabling the outputs
14	HVM	V-phase Hall-signal input (-)
15	HVP	V-phase Hall-signal input (+)
16	HUM	U-phase Hall-signal input (-)
17	HUP	U-phase Hall-signal input (+)
18, 19	V <sub>refout</sub>	Reference voltage output (V <sub>refout</sub> = 4.4 V (typ.), I <sub>refout</sub> = 20 mA (max)), connection pin for an oscillation prevention capacitor
20	ML	Restart operation select input for the anti-lock system
21	LL	Lower limit control for lead angle
22	UL	Upper limit control for lead angle
23	LA	Lead angle select input (This input is used to determine the lead-angle under the automatic lead-angle control.)
24	IV	Voltage output converted from the output current
25	LPF	Connection pin for a filter capacitor
26	PH	Connection pin for a peak-hold capacitor
27	Gout	Amplified shunt voltage
28	G <sub>in-</sub>	Connection pin for an amplifier resistor
29	G <sub>in+</sub>	Shunt voltage input
30	RS	Overcurrent protection input (Disables outputs when RS ≥ 0.5 V)
31	P-GND	Power ground
32	IR	Connection pin for an output shunt resistor
33	W	W-phase output
34	V	V-phase output
35	U	U-phase output

**I/O Equivalent Circuits**

Some parts are omitted from the equivalent circuit diagrams or simplified for the sake of simplicity.

Pin Description	Symbol	I/O Signal	Internal Circuit Diagram
Position signal inputs	HUP HUM HVP HVM HWP HWM	Analog  Hysteresis: $\pm 8$ mV (typ.)	
Speed control input	VSP	Analog  Input range: 0 to Vrefout	
Rotation direction select input  L: Clockwise (CW) H: Counterclockwise (CCW)	CW/CCW	Digital  L: 0.8 V (max) H: 2.0 V (min)  Hysteresis: 200 mV (typ.)	
Reset input  L: Drives a motor H: Reset	RESET	Digital  L: 0.8 V (max) H: 2.0 V (min)  Hysteresis: 200 mV (typ.)  At reset: Outputs are disabled; internal counter keeps running.	
Lead angle control input  0 V: 0° 3.0 V: 28° (5-bit AD converter)	LA	When fixing the lead angle externally, connect LL to GND and UL to Vrefout. Also, apply a control voltage to the LA pin.  Input range: 0 to 4.4 V (Vrefout) When an input voltage of 3.0 V or higher is applied, the lead angle is clipped to a maximum of 28°.  The LA pin should be left open when using the automatic-lead-angle control. At this time, the LA pin can be used for determining the lead angle.	

Pin Description	Symbol	I/O Signal	Internal Circuit Diagram
Gain control inputs (Lead-angle controller)	$G_{in-}$ $G_{in+}$ $G_{out}$	Non-inverting amplifier 25dB (max) $G_{out}$ output voltage Low: GND High: $V_{refout} - 0.4\text{ V}$	
Peak-hold (Lead-angle controller)	PH	This pin is connected to a peak-hold capacitor and a discharge resistor. 100 k $\Omega$ /0.1 $\mu$ F	
Low-pass filter (Lead-angle controller)	LPF	This pin is connected to an RC filter (low-pass filter) capacitor. This pin has an internal resistor of 100 k $\Omega$ (typ.). 0.1 $\mu$ F	
Lead-angle lower-limit control	LL	The lead angle is clipped to the lower limit. $LL = 0\text{ V}$ to 4.4 V ( $V_{refout}$ ) When $LL > UL$ , LA is fixed to the value determined by LL.	
Lead-angle upper-limit control	UL	The lead angle is clipped to the upper limit. $UL = 0\text{ V}$ to 4.4 V ( $V_{refout}$ ) When $LL > UL$ , LA is fixed to the value determined by LL.	

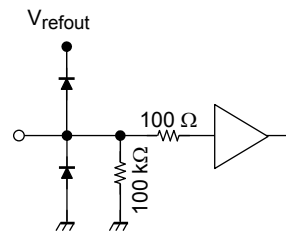
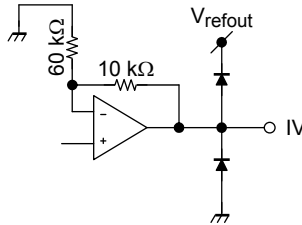
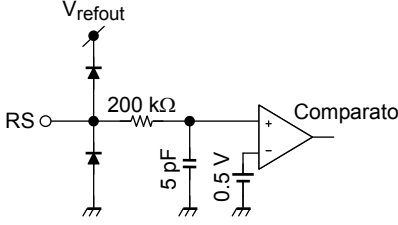
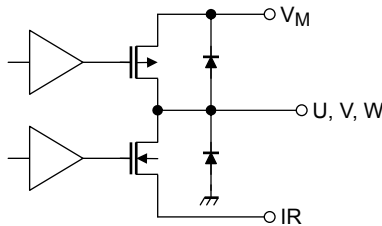
Pin Description	Symbol	I/O Signal	Internal Circuit Diagram
Restart operation select input for the anti-lock system L: Restart with power cycling H: Automatic restart	ML	Digital L: 0.8 V (max) H: 2.0 V (min)	
Voltage output converted from output current	IV	Analog IV = 0.5 V to 3.5 V ( $\pm 2$ mA (max)) Gain = 1.2 (typ.)	
Current-limiting input	RS	Analog Digital filter: 1 $\mu$ s (typ.) The gate block protection is activated when RS reaches 0.5 V. (Disabled every carrier cycle)	
U-phase, V-phase and W-phase outputs	U V W	Motor drive output I <sub>OUT</sub> = 1.2 A (typ.) 1.8 A (max)	

## Absolute Maximum Ratings (Ta = 25°C)

Characteristics	Symbol	Rating	Unit
Power supply voltage	V <sub>M</sub>	45	V
Input voltage	V <sub>IN</sub>	4.7	V
Output current	I <sub>OUT</sub>	1.8 (Note 1)	A
Power dissipation	P <sub>D</sub>	1.3 (Note 2)	W
		3.2 (Note 3)	
Operating temperature	T <sub>opr</sub>	-30 to 85	°C
Storage temperature	T <sub>stg</sub>	-55 to 150	

Note 1: Output current may be limited by the ambient temperature or a heatsink. The maximum junction temperature should not exceed T<sub>jmax</sub> = 150°C.

Note 2: Measured for the IC only. (Ta = 25°C)

Note 3: Measured on a board. (100 mm × 200 mm × 1.6 mm, Cu: 50%)

## Operating Ranges (Ta = 25°C)

Characteristics	Symbol	Min	Typ.	Max	Unit
Power supply voltage	V <sub>M</sub>	4.5	24	42	V
Oscillation frequency bandwidth	F <sub>OSC</sub>	4	5	6	MHz

## Package Power Dissipation

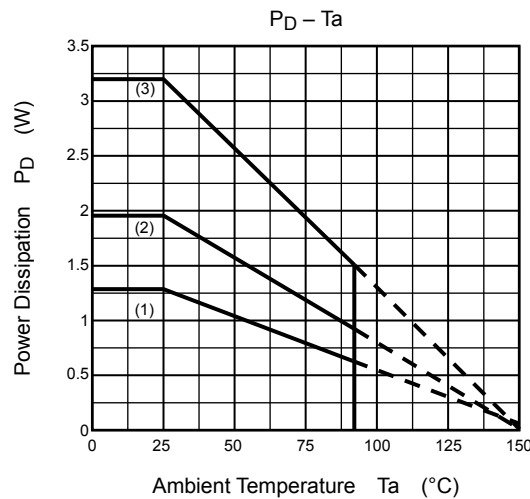

- (1) R<sub>th(j-a)</sub>: (96°C/W)
- (2) Measured on a board (114 mm × 75 mm × 1.6 mm, Cu 20%: 65°C/W)
- (3) Measured on a board (140 mm × 70 mm × 1.6 mm, Cu 50%: 39°C/W)

## Electrical Characteristics (Ta = 25°C, VM = 24 V)

Characteristics		Symbol	Test Conditions	Min	Typ.	Max	Unit	
Power supply current		IM	Pre-drive current + control current, Irefout = 0 mA	—	7	14	mA	
Input current		Iin (1)	Vin = 4.4 V LA	—	22	40	μA	
		Iin (2)	Vin = 4.4 V Vsp	—	30	60		
		Iin (3)	Vin = 4.4 V RESET, ML, CW/CCW	—	44	80		
Hall amplifier	In-phase input voltage range	VCMRH		1.5	—	3.5	V	
	Input voltage swing	VH		50	—	—	mVpp	
	Input hysteresis	VhysH	(Note)	±4	±8	±12	mV	
	Input current	IinH	VCMRH = 2.5 V, single phase	-1	—	1	μA	
Input voltage		Vin	High	CW/CCW, RESET, ML	2.0	—	Vrefout + 0.2	V
			Low		0	—	0.8	
		Vin Hys	CW/CCW, RESET, ML	—	0.2	—		
		Vsp (4.4)	Modulated wave: max	Vrefout - 0.2	—	Vrefout + 0.2		
		Vsp (0.5)	Commutation OFF → Start motor operation	0.3	0.5	0.7		
Output ON-resistance		RON (H+L)	IOUT = 1.2 A U, V, W	—	0.7	1.0	Ω	
			IOUT = 1.6 A U, V, W	—	0.7	1.0		
Vrefout output voltage		Vrefout	Irefout = 20 mA Vrefout	4.0	4.4	4.8	V	
FG output voltage		VFG (H)	IOUT = 1 mA FG	Vrefout - 1.0	Vrefout - 0.2	—	V	
		VFG (L)	IOUT = -1 mA FG	—	0.2	1.0		
Output leakage current		IL (H)	VOOUT = 0 V	—	0	1	μA	
		IL (L)	VOOUT = 24 V	—	0	1		
Current detection		VRS	RS	0.46	0.5	0.54	V	
Input delay		TRS	RS → Output off	—	2.0	—	μs	
Gain-controlling amplifier for lead-angle controller		AMP <sub>OUT</sub>	G <sub>OUT</sub> output current, I <sub>OUT</sub> = 5 mA, G <sub>IN+</sub> = 0.2 V G <sub>IN-</sub> , G <sub>OUT</sub> : Gain = 12 (11 kΩ/1 kΩ)	2.25	2.3	—	V	
		AMP <sub>OFS</sub>	G <sub>IN</sub> , G <sub>OUT</sub> 11 kΩ/1 kΩ	—	-40	—	mV	
Voltage error for lead-angle limit control		ΔL	LL = 0.7 V	-20	—	20	mV	
		ΔU	UL = 2.0 V	-30	—	30		
PH output current for lead-angle controller		PH <sub>OUT</sub> (0 mA)	PH output current, I <sub>OUT</sub> = 0 mA, G <sub>OUT</sub> = 2.4 V	2.35	2.4	2.45	V	
		PH <sub>OUT</sub> (5 mA)	PH output current, I <sub>OUT</sub> = 5 mA, G <sub>OUT</sub> = 2.4 V	—	1.9	—		
Lead angle correction		T <sub>LA</sub> (0)	LA = 0 V or Open, Hall IN = 100 Hz	—	0	—	°	
		T <sub>LA</sub> (1.5)	LA = 2.5 V, Hall IN = 100 Hz	—	15	—		
		T <sub>LA</sub> (3)	LA = 5 V, Hall IN = 100 Hz	—	29	—		
Automatic restart from motor lock		T <sub>ML</sub> (ON)	Lock detection time, TR = 180 pF	—	500	—	ms	
		T <sub>ML</sub> (OFF)	Output off time when ML = High, TR = 180 pF	—	500	—		
		F <sub>TR</sub>	Oscillation frequency, TR = 180 pF	1.5	2.0	2.5		kHz
VM power supply monitor		VM (H)	Output start point	3.8	4.0	4.2	V	
		VM (L)	Output stop point	3.3	3.5	3.7		
		VH	Hysteresis width	—	0.5	—		
PWM frequency		FC (5M)	OSC/C = 150 pF OSC/R = 16 kΩ	18	20	22	kHz	
Thermal shutdown		TSD	(Note)	150	165	180	°C	
		TSDhys	Thermal shutdown hysteresis	—	15	—		

Note: Product testing before shipment is not performed.

**Functional Description**

**1. Basic Operation**

At startup, the motor is driven by a square-wave commutation signal that is generated based on the position detection signal. When the position detection signal exceeds the rotational frequency of  $f = 2.5$  Hz, the rotor position is determined by the position detection signal and the modulated wave signal is generated. Then, the sine-wave PWM signal is generated by comparing the modulated wave signal with the triangular wave signal to start a motor in PWM drive mode.

Startup to 2.5 Hz: Square-wave drive (120° commutation)  $f = f_{osc}/(2^{12} \times 32 \times 6)$

2.5 Hz or higher: Sine-wave PWM drive (180° commutation)  $f \approx 2.5$  Hz when  $f_{osc} = 5$  MHz

**2. Speed Control Input (Vsp)**

- (1) Speed control input:  $0\text{ V} < V_{sp} \leq 0.5\text{ V}$   
The motor-driving output is turned off. (Motor is stopped.)
- (2) Speed control input:  $V_{sp} > 0.5\text{ V}$   
When  $f_{osc} = 5$  MHz, the motor is driven by a square wave until  $f$  reaches 2.5 Hz. Then, the motor-driving signal is switched to a sine-wave signal.

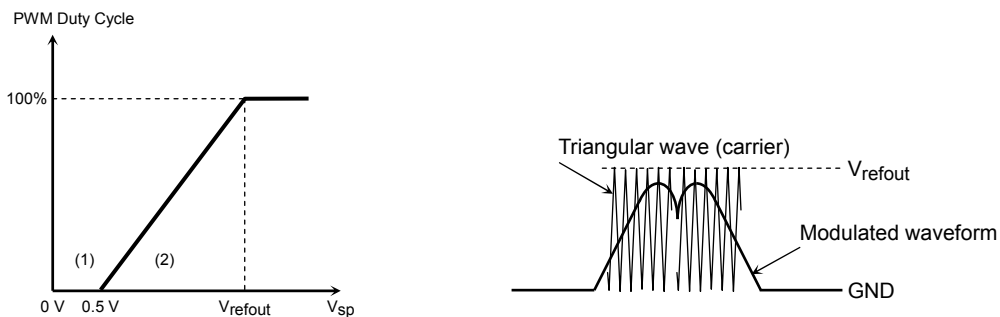

Note: An amplitude of the modulated waveform becomes maximum when  $V_{SP} = V_{refout}$ . The PWM duty cycle that is obtained with the  $V_{SP}$  voltage of  $V_{refout}$  is defined as 100%.

**3. Carrier Frequency Setting**

The frequency of the triangular wave (carrier frequency) required for the PWM signal generation is fixed at the following value:

$f_c = f_{osc}/252$  (Hz), where  $f_{osc}$  = Reference clock frequency (RC oscillator frequency)

Example: When  $f_{osc} = 5$  MHz,  $f_c = 19.8$  kHz

**4. Lead Angle Correction**

The lead angle of the motor driving signal generated in accordance with the induced voltage (Hall signal) is corrected by an angle between 0 and 30°.

The lead angle control can be achieved by directly applying a voltage to the PA pin, or by using the motor current.

**<Simplified Diagram of the LA Pin>**

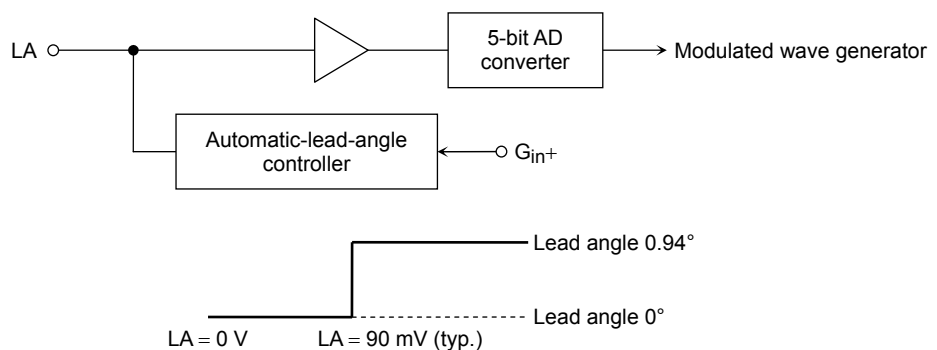

### <Typical Characteristics of the LA versus Lead Angle>

Step	LA (V)	Lead angle (°)	Step	LA (V)	Lead angle (°)
1	0.00	0.00	17	1.50	15
2	0.09	0.94	18	1.59	15.94
3	0.19	1.88	19	1.69	16.88
4	0.28	2.81	20	1.78	17.81
5	0.38	3.75	21	1.88	18.75
6	0.47	4.69	22	1.97	19.69
7	0.56	5.63	23	2.06	20.63
8	0.66	6.56	24	2.16	21.56
9	0.75	7.5	25	2.25	22.50
10	0.84	8.44	26	2.34	23.44
11	0.94	9.38	27	2.44	24.38
12	1.03	10.31	28	2.53	25.31
13	1.13	11.25	29	2.63	26.25
14	1.22	12.19	30	2.72	27.19
15	1.31	13.13	31	2.81	28.13
16	1.41	14.06	32	2.91	29.06

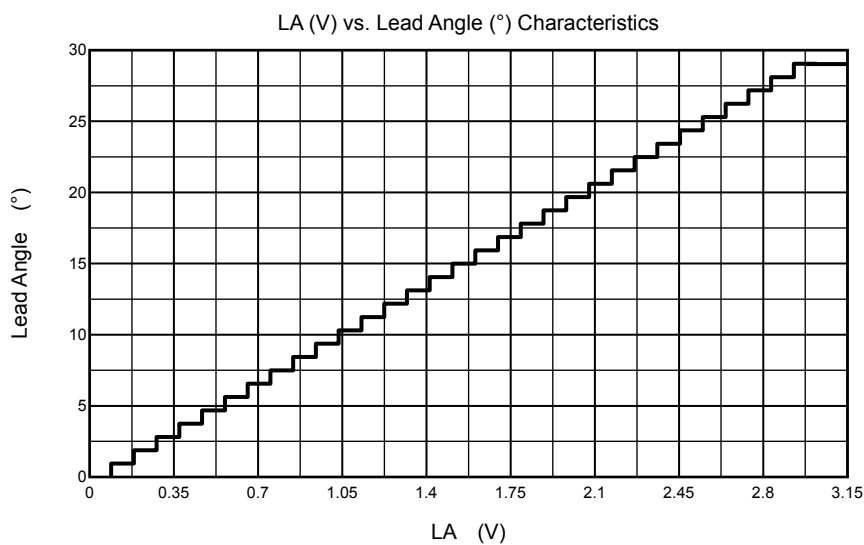

<Simplified Diagram of the Automatic-Lead-Angle Correction Circuitry>

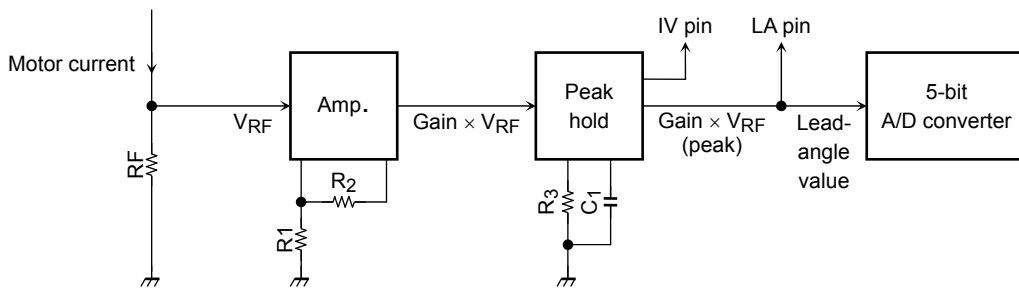

\*: Gain = (R<sub>1</sub> + R<sub>2</sub>) / R<sub>1</sub>, R<sub>3</sub> = 100 kΩ, C<sub>1</sub> = 0.1 μF

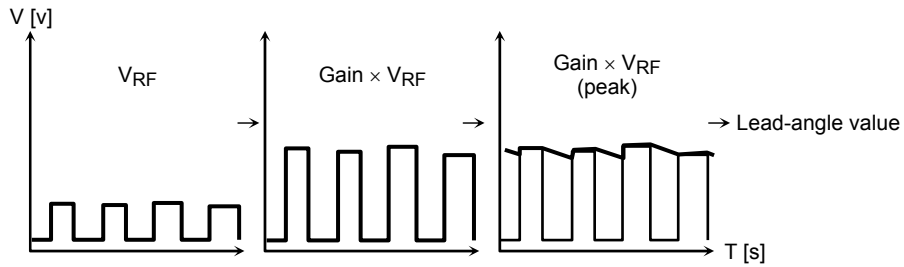

**5. Position Detection (Hall effect input)**

The in-phase input voltage range, V<sub>CMRH</sub>, is from 1.5 to 3.5 V. The input hysteresis, V<sub>H</sub>, is 8 mV (typ.).

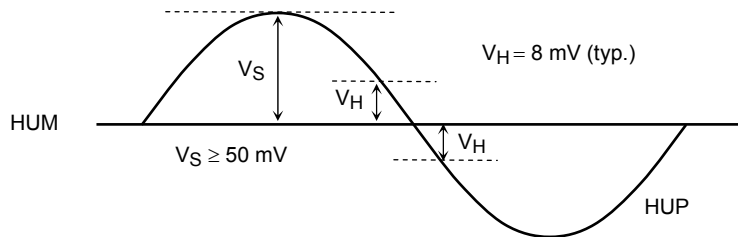

\*: The Hall amplifier can operate when V<sub>S</sub> is at least 50mVpp. However, to stabilize the time interval between zero-cross points of each phase signal, that is, the 60-electrical-degree interval, the amplitude should be as high as possible. (V<sub>S</sub> is recommended to be 200 mVpp or higher.)

**6. Rotation Pulse Output (FG output)**

This pin generates a rotation pulse (3 pulses/electrical degree).

Example: With an eight-pole motor, 12 pulses are generated per revolution. (12 ppr)

**7. Reverse Rotation Detection**

The direction of the motor rotation is detected. The drive mode is then selected between 120° commutation and 180° commutation modes.

The detection is performed at every electrical degree of 360°.

CW/CCW Pin	Actual Rotation Direction of the Motor	Commutation Mode
Low (CW)	CW (clockwise)	180° commutation
	CCW (counterclockwise)	120° commutation
High (CCW)	CW (clockwise)	120° commutation
	CCW (counterclockwise)	180° commutation

Note: When the Hall signal frequency is below 2.5 Hz, the TB6585FG is put in 120° commutation mode even when 180° commutation mode is selected.

**8. Various Protections**

- (1) Overcurrent Protection (RS pin)  
When a DC link current exceeds the internal reference voltage, output transistors are turned off. The TB6585FG exits overcurrent protection mode every carrier cycle. Reference voltage = 0.5 V (typ.)
- (2) External RESET (RESET pin)  
Output transistors are turned off when RESET is High; they are turned on again when RESET is Low or Open.  
The RESET pin is activated if any abnormality is detected externally.
- (3) Internal Protections
  - Position Detection Fault Protection  
When the position detection signals are all set to High or Low, output transistors are turned off. Otherwise, the motor is restarted every carrier cycle.
  - Anti-lock capability  
When the operation mode is not properly switched as configured from 120° commutation mode of startup operation to 180° commutation mode, the motor is deemed to be locked and output transistors are turned off. The restart operation can be selected from either the automatic restart or the power cycling.

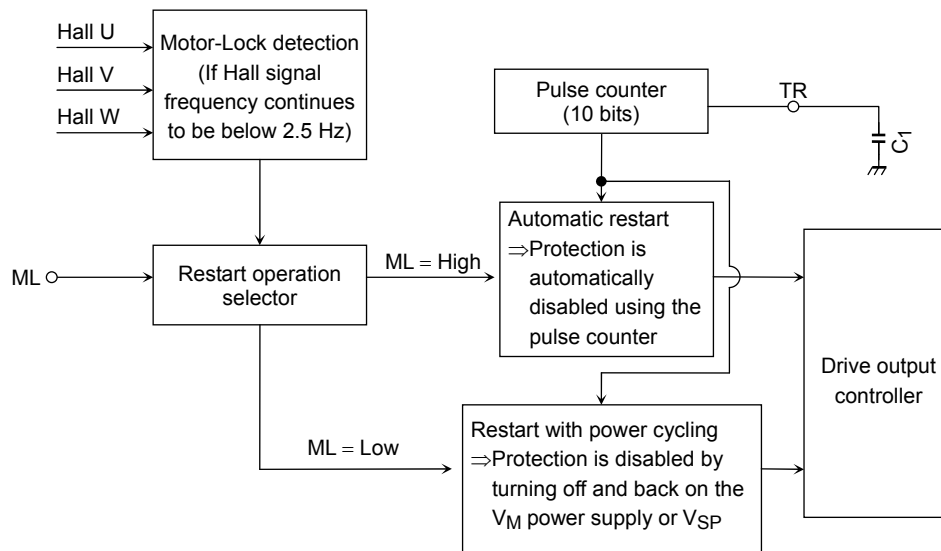

<Setting the Time of Motor-Lock Detection and the Time While the Motor is Stationary>

The time required for the motor-lock detection and the time while the motor driving signal is inactive can be adjusted by the external capacitor C<sub>1</sub>. (These periods are set to be the same.)

$$\text{Time setting} \quad T = \frac{C_1 \times V_{th}}{I} \times 1024(\text{s}) \quad I = 0.72 \mu\text{A}, V_{th} = 2 \text{ V}$$

Example: When C<sub>1</sub> = 180 pF, T ≈ 500 ms (typ.).

<Automatic Restart (ML = High)>

When the Hall signal frequency is kept below 2.5 Hz for at least 500 ms (typ.), the TB6585FG becomes active and inactive periodically every 500 ms (typ.). The protection is disabled when the Hall signal frequency reaches 2.5 Hz and the operation mode is switched to 180° commutation mode.

<Restart with Power Cycling (ML = Open or Low)>

When the Hall signal frequency is kept below 2.5 Hz for at least 500 ms (typ.), output transistors are disabled. The TB6585FG can be restarted by turning off and back on the V<sub>M</sub> power supply, which must be kept below 3.5 V (typ.). The TB6585FG can also be restarted by turning off and back on V<sub>sp</sub>, which must be kept below 1 V (typ.).

- Undervoltage Protection ( $V_M$  Power Supply Monitoring)  
 When the  $V_M$  power supply is turned on or off, commutation signal outputs are disabled while  $V_M$  is outside the operating voltage range.

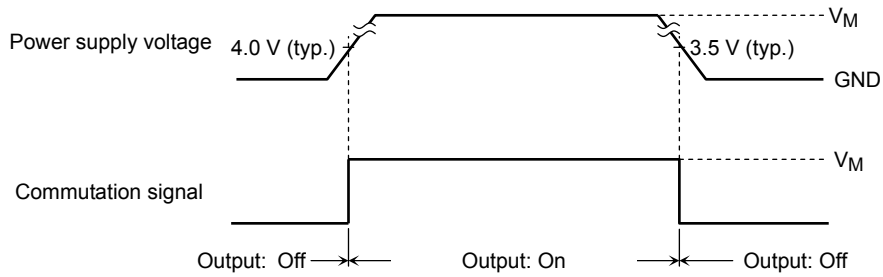

## Operation Flow

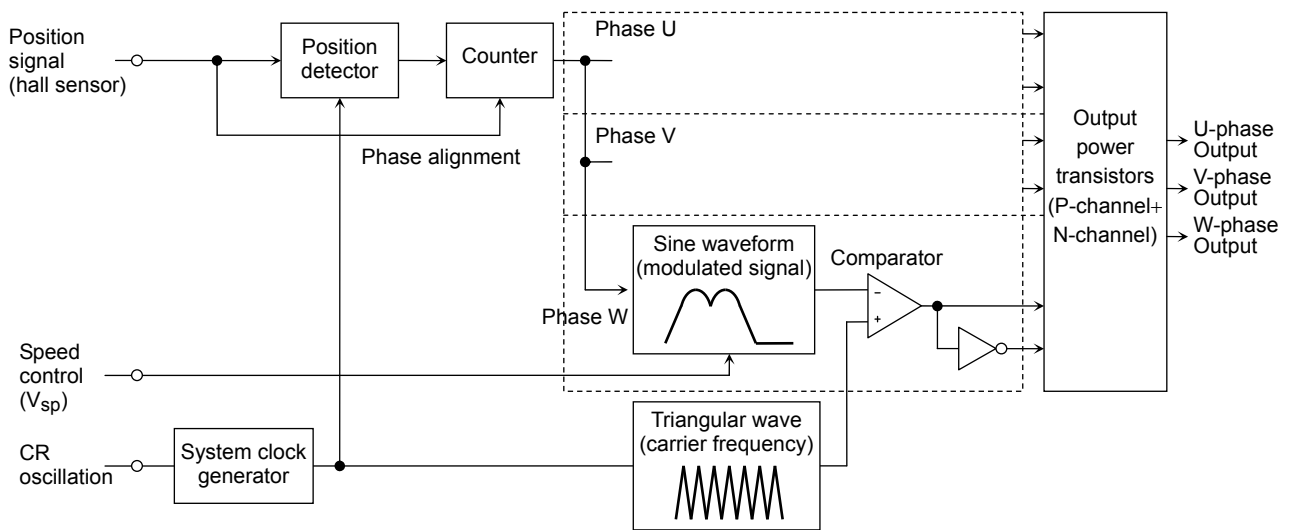

<Sine-Wave PWM Signal Generation>

The modulated waveform is generated using the Hall signals. The sine-wave PWM signal is then generated by comparing the modulated waveform with the triangular wave.

The time between the rising edges (falling edges) and the immediately-following falling edges (rising edges) of any of the three Hall signals (interval of 60 electrical degrees) are calculated by the counter. This period is used for data generation of the next 60-electrical-degree interval.

The modulated waveform of 60-electrical-degree interval consists of 32 data items. The time period for a single data item is 1/32 of the previous 60-electrical-degree interval. The modulated waveform advances by this period. (Operating waveforms when CW/CCW = Low)

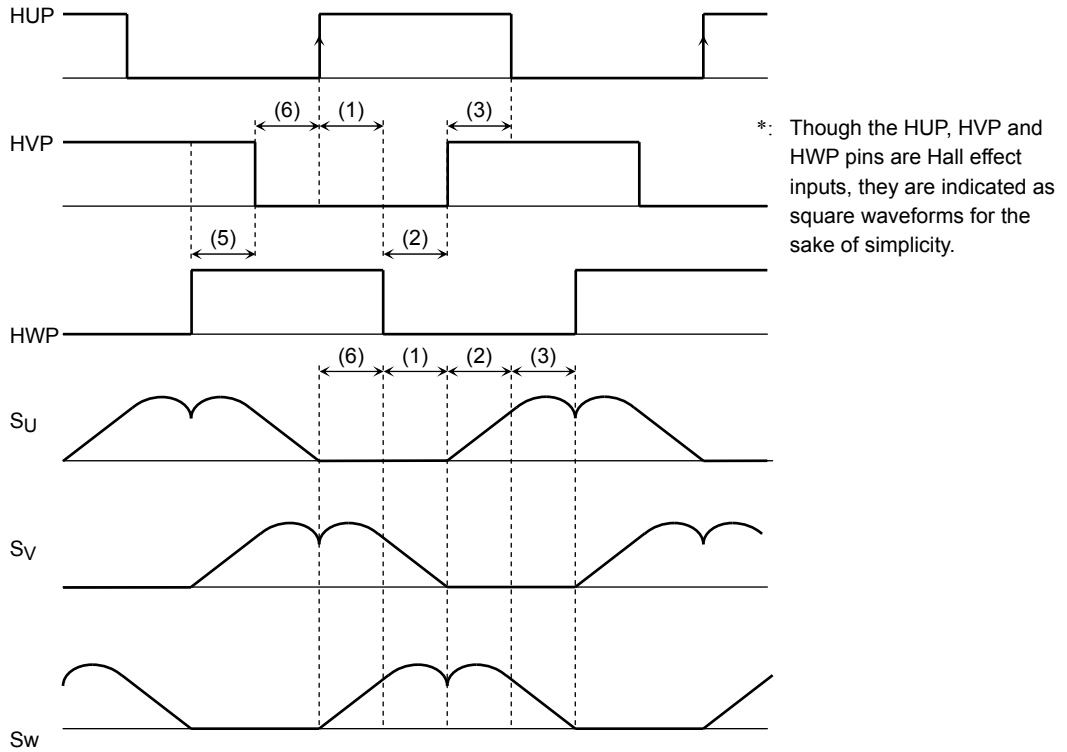

As illustrated above, the modulated waveform (1)' advances by 1/32 of the period between the rising edge (↑) of HU and the falling edge (↓) of HW. Likewise, the modulated waveform (2)' advances by 1/32 of the period between the falling edge (↓) of HW and the rising edge (↑) of HV.

If the next edge does not occur even after completing the generation of 32 data, data for the next 60-electrical-degree interval are generated based on the same time period until the next edge occurs.

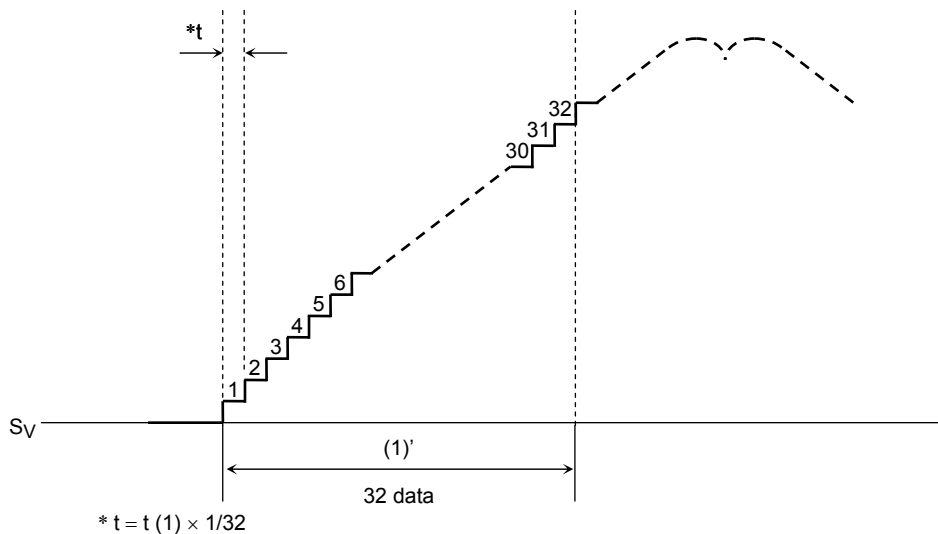

Also, the phase alignment with the modulated waveform is performed at every zero-cross point. The modulated waveform is reset by being synchronized with the rising and falling edges of the position detection signal at every 60 electrical degrees. Therefore, the modulated waveform becomes discontinuous

at every reset if there occurs a zero-cross point error of the Hall signal, or when motor is being accelerated or decelerated.

Also, the phase alignment with the modulated waveform is performed at every zero-cross point.

The modulated waveform is reset by being synchronized with the rising and falling edges of the position detection signal (Hall amplifier output) at every 60 electrical degrees.

Therefore, if the next zero-cross point occurs before completing the generation of 32 data for 60-electrical-degree interval due to the zero-cross point error of the position detection signal, the current data is reset and the data generation for the next 60-electrical-degree interval is then started.

In such cases, the modulated waveform is discontinuous at every reset.

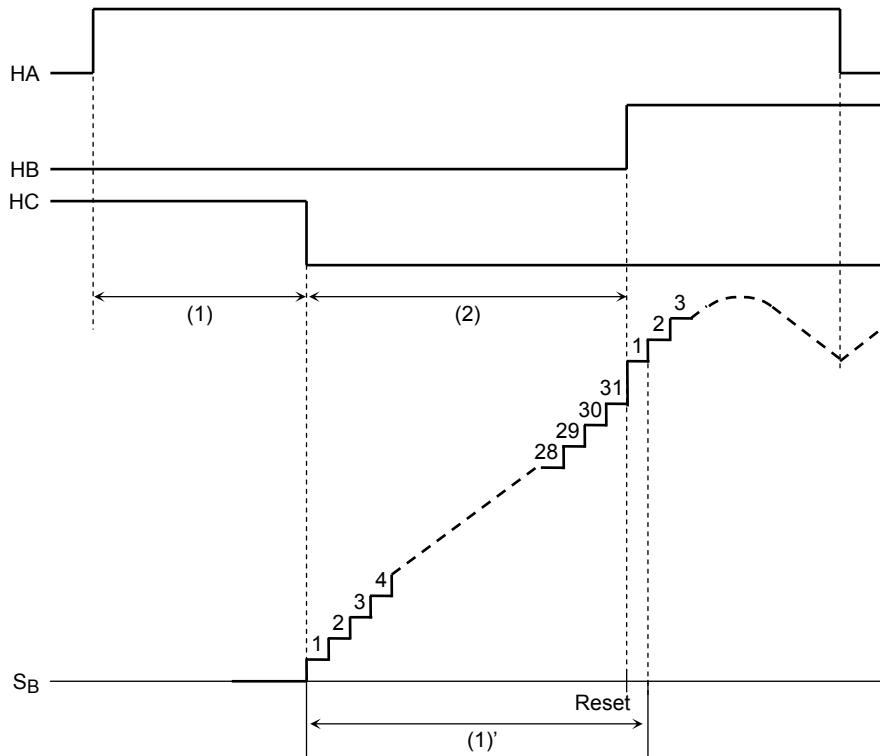

**<Output Waveform of the Sine-Wave PWM Drive>**

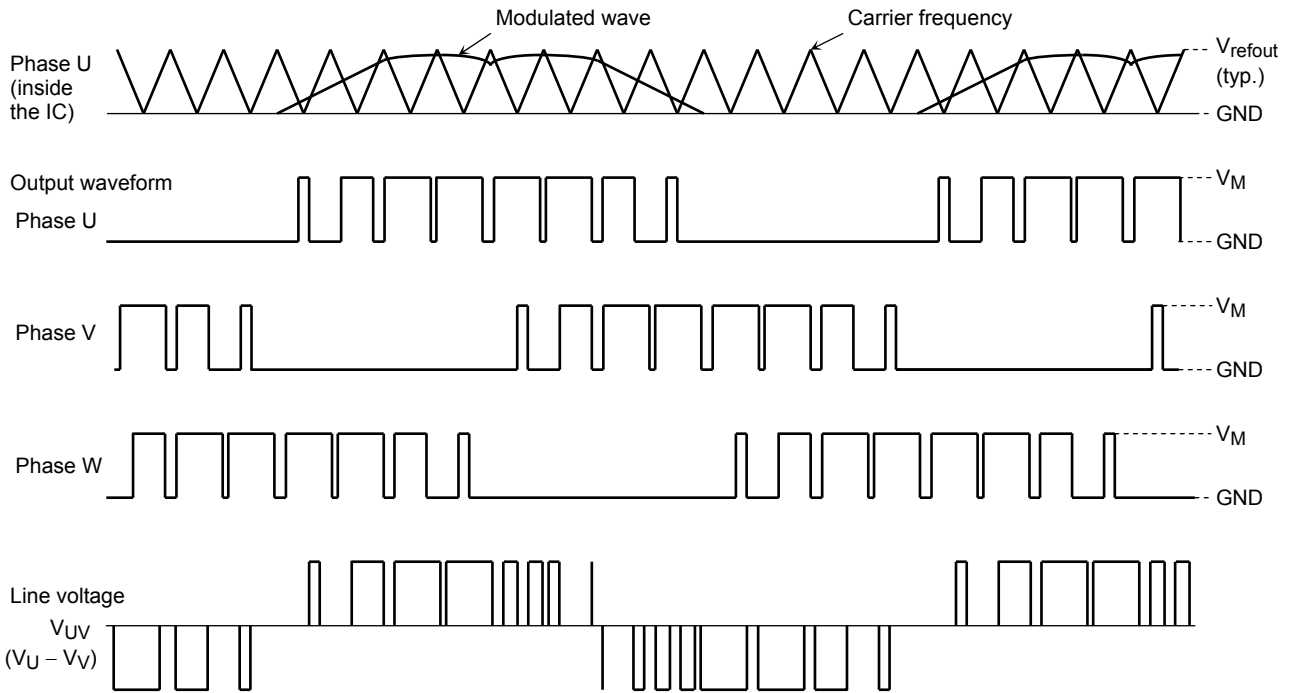

**<Output Waveform of the Square-Wave Drive>**

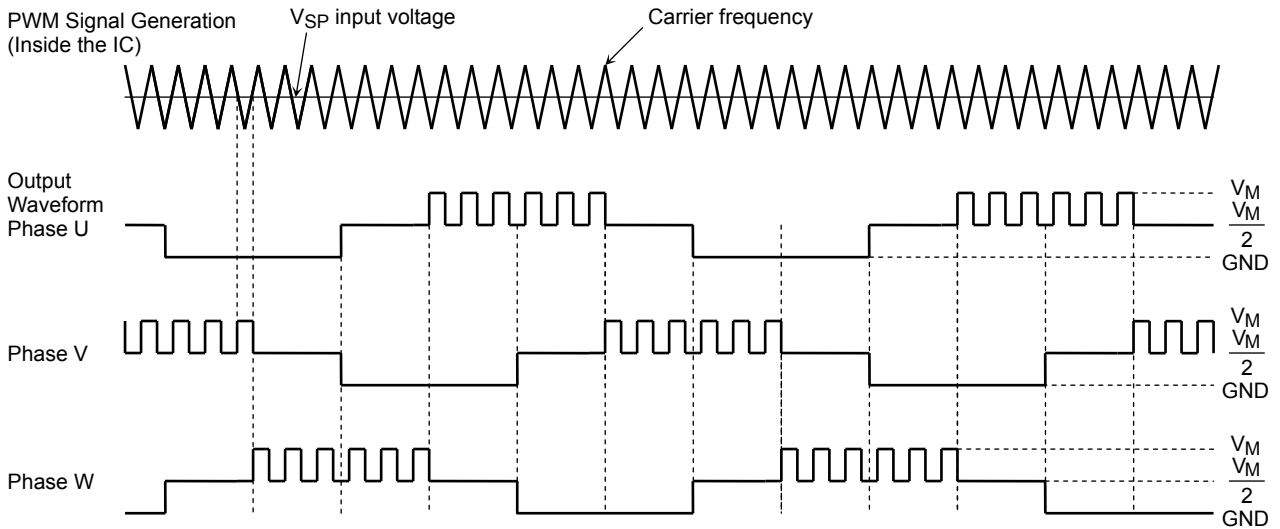

Note: The above U-phase waveform shows the behavior of the U-phase output signal when a resistor is connected between the U and VM pins and also between the U pin and ground to obtain  $\frac{V_M}{2}$ . Likewise, resistors are connected to the V and W pins.  $\frac{V_M}{2}$  indicates the high-impedance state.

**Timing Chart of the Clockwise Rotation (CW/CCW = Low, LA = GND)**

(Hall Signal Input for Clockwise Rotation)

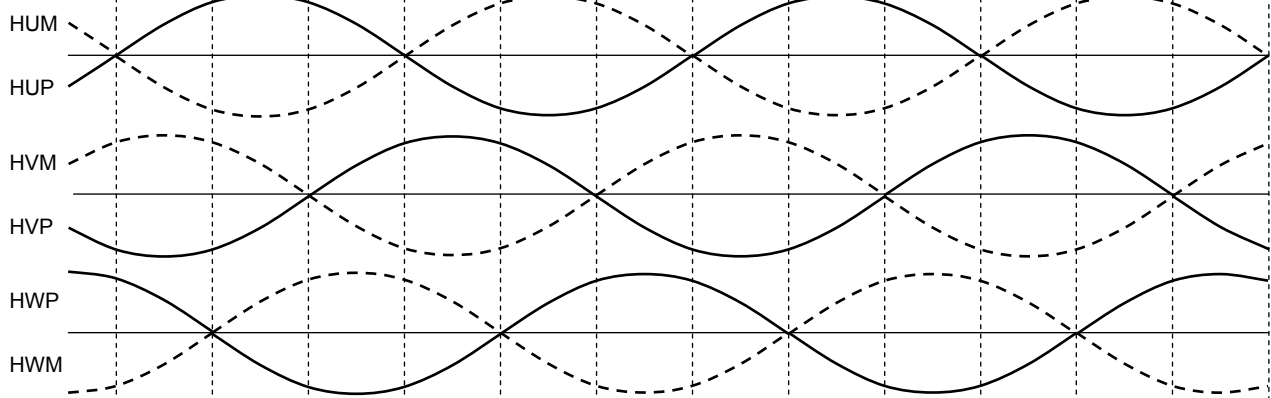

0 < Hall signal frequency < 2.5 Hz  
(120° commutation)

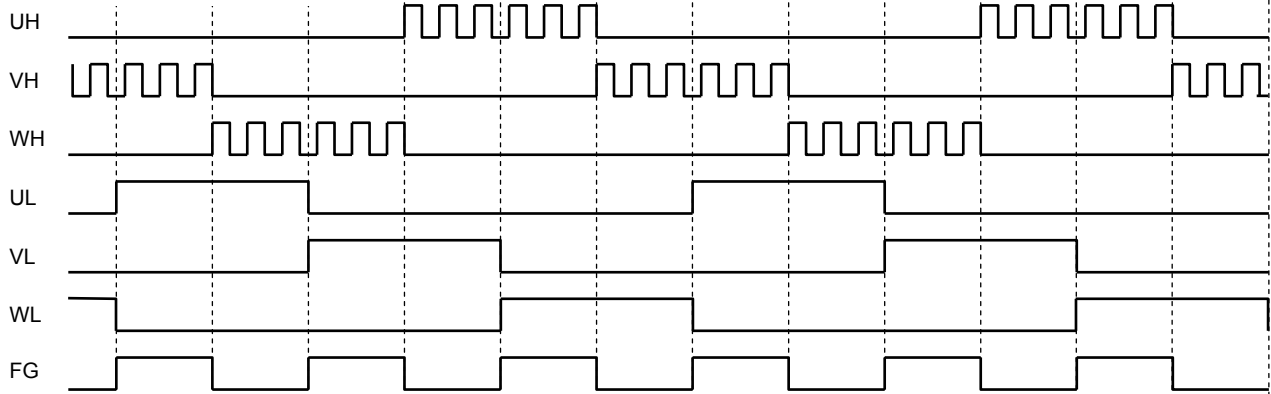

2.5 Hz < Hall signal frequency  
(180° commutation: Modulated wave inside the IC)

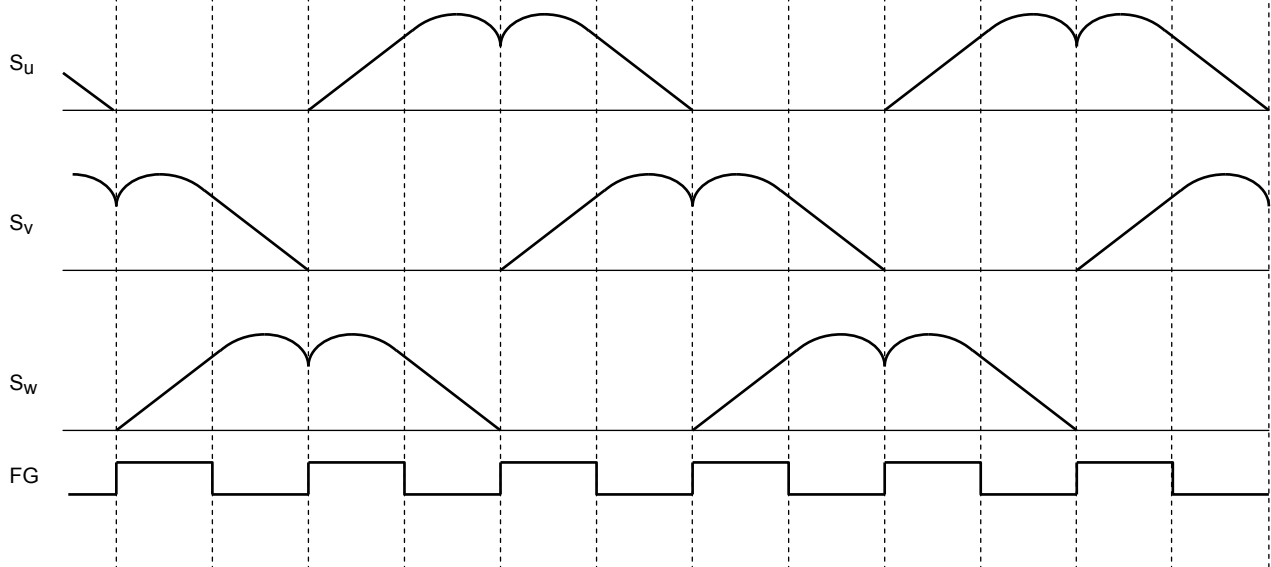

\*: The lead-angle correction is performed in accordance with the LA input when the Hall signal frequency is 2.5 Hz or higher.

The timing chart may be simplified for the sake of brevity.

**Timing Chart of the Clockwise Rotation (CW/CCW = Low, LA = GND)**

(Hall Signal Input for Counterclockwise Rotation)

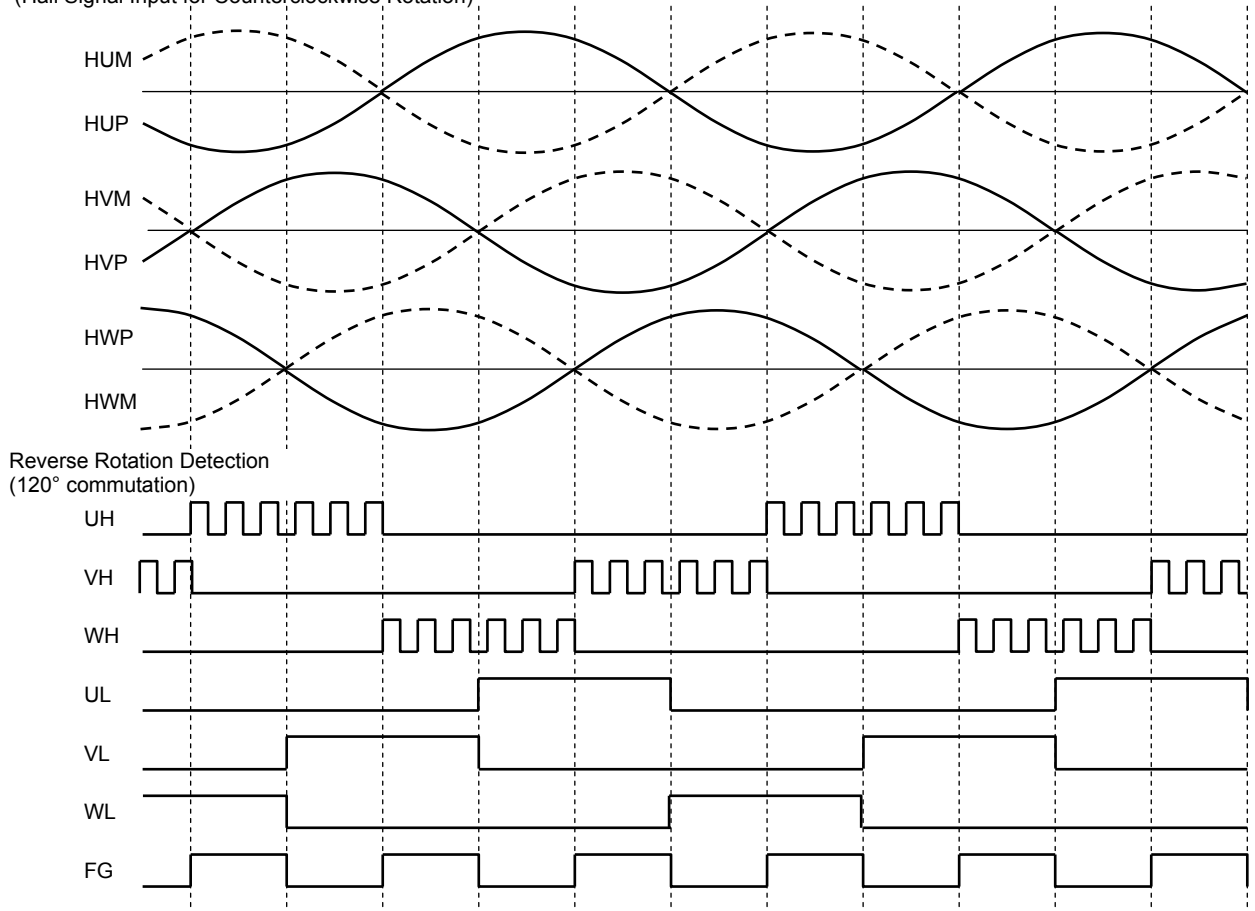

\*: If the Hall signal for counterclockwise rotation is applied when CW/CCW = Low, the motor is driven by the 120° commutation signal with a lead angle of 0°. (Reverse rotation by the wind)

The timing chart may be simplified for the sake of brevity.

**Timing Chart of the Counterclockwise Rotation (CW/CCW = High, LA = GND)**

(Hall Signal Input for Counterclockwise Rotation)

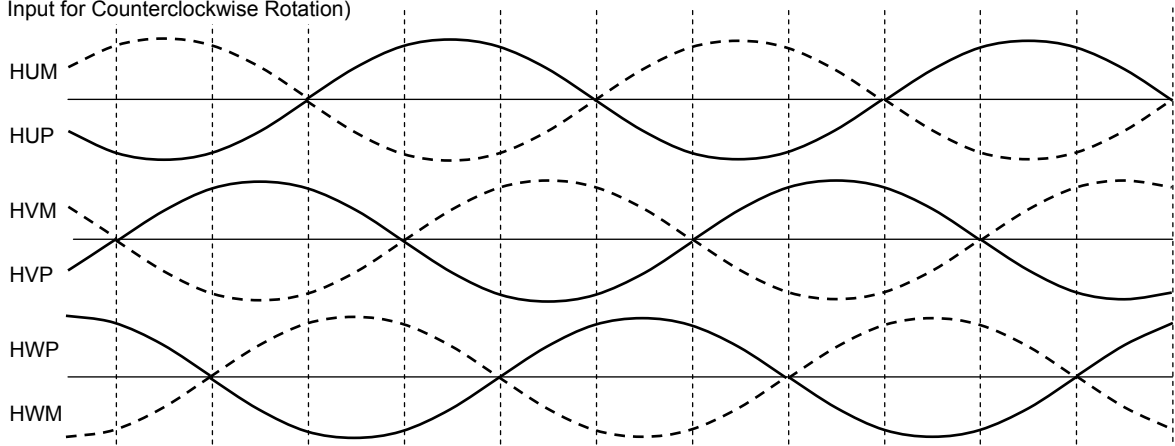

0 < Hall signal frequency < 5 Hz  
(120° commutation)

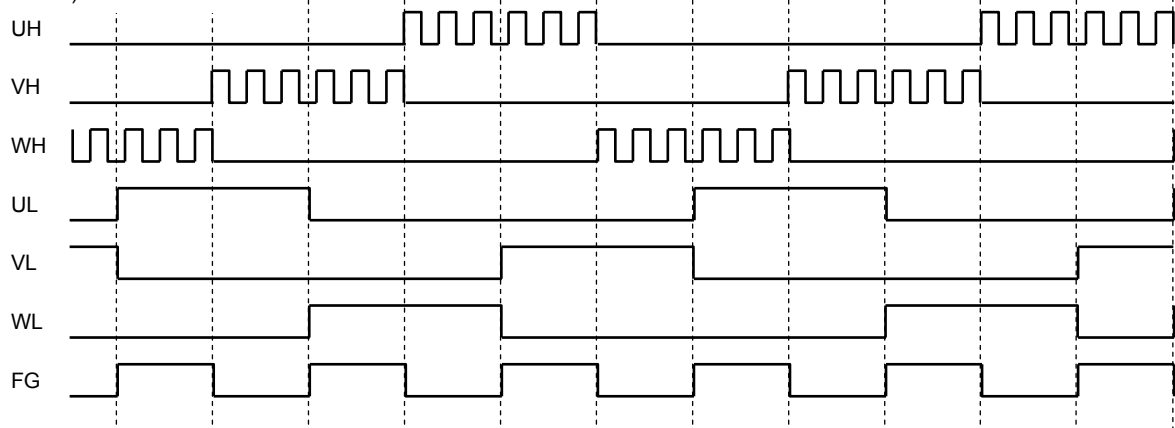

5 Hz < Hall signal frequency  
(180° commutation: Modulated wave inside the IC)

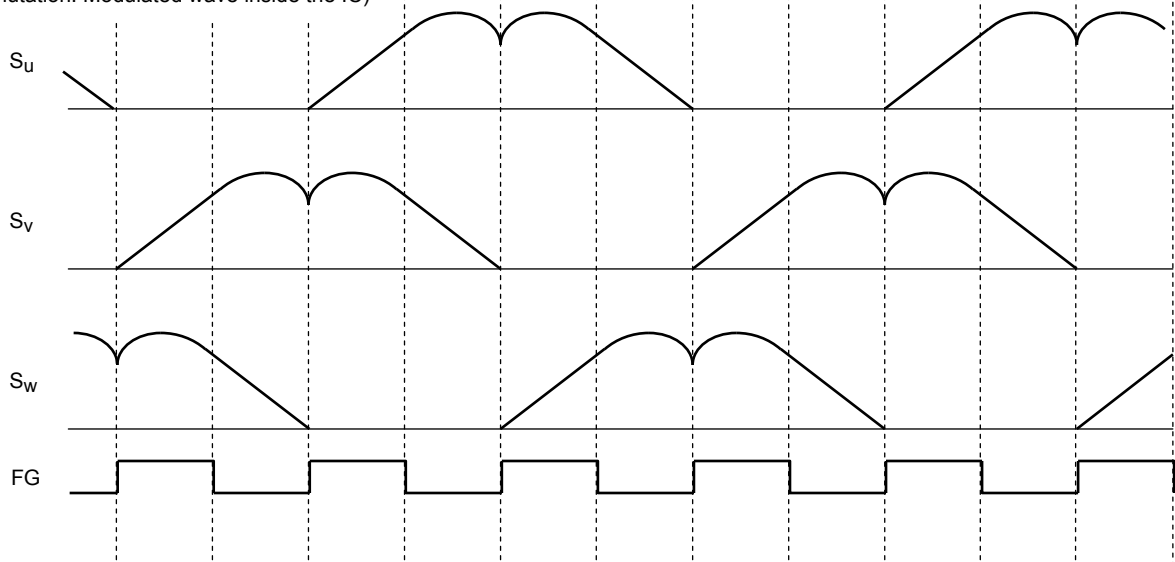

\*: The lead-angle correction is performed in accordance with the LA input when the Hall signal frequency is 2.5 Hz or higher.

The timing chart may be simplified for the sake of brevity.

**Timing Chart of the Counterclockwise Rotation (CW/CCW = High, LA = GND)**

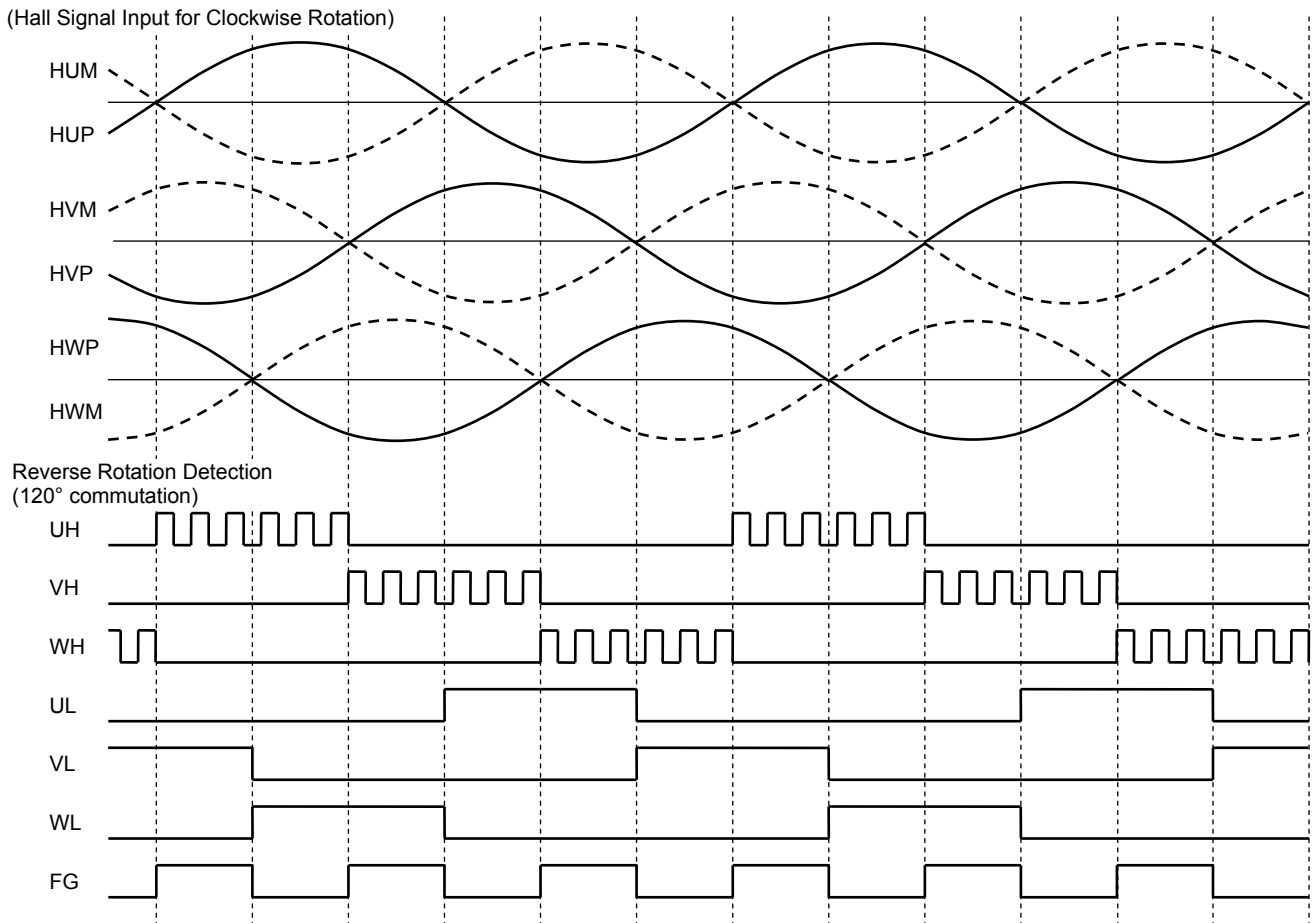

\*: If the Hall signal for clockwise rotation is applied when CW/CCW = High, the motor is driven by the 120° commutation signal with a lead angle of 0°. (Reverse rotation by the wind)

The timing chart may be simplified for the sake of brevity.

## Block Diagram

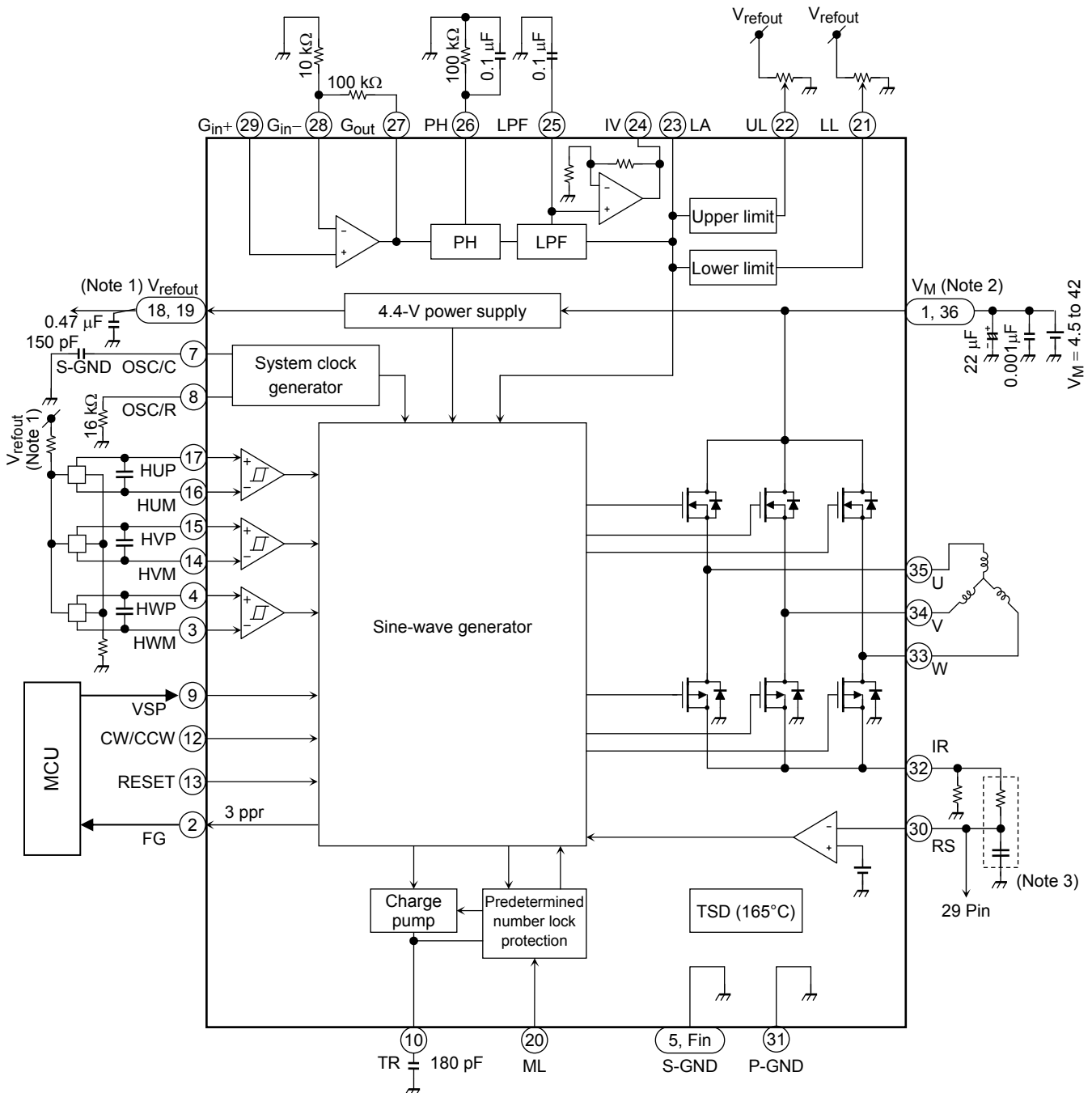

Note 1: An oscillation prevention capacitor should be connected to the  $V_{refout}$  pin at a location as close to the TB6585FG as possible.

If the package's thermal performance is not enough for the application, a load must not be connected to the  $V_{refout}$  output; instead, a voltage of 4.4 V must be applied externally to it.

Note 2: An oscillation prevention capacitor should be connected to the  $V_M$  pin at a location as close to the TB6585FG as possible.

Note 3: If there is a significant noise, an RC filter (low-pass filter) should be connected.

Note 4: A large current or voltage might be abruptly applied to the IC and peripherals in case of a short-circuit across outputs, a short-circuit to power supply or a short-circuit to ground. This possibility should be fully considered in the design of the output,  $V_M$ , IR and ground lines. Also, care should be taken not to install the IC in the wrong orientation. Otherwise, IC may be broken.

Note 5: The constants of loads that are connected externally to the IC shown in the above diagram are used as initial values to determine whether the application operates properly. The capacitor values that are connected to  $V_M$ ,  $V_{refout}$ , and between positive and negative inputs of Hall elements must be determined experimentally.

## Package Dimensions

HSOP36-P-450-0.65

Unit: mm

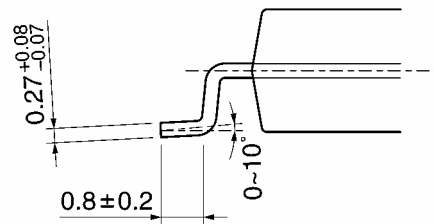
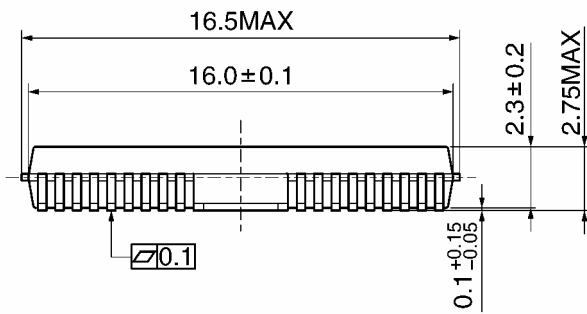
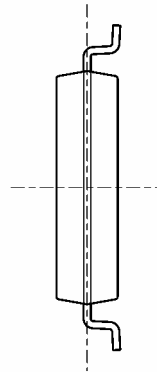
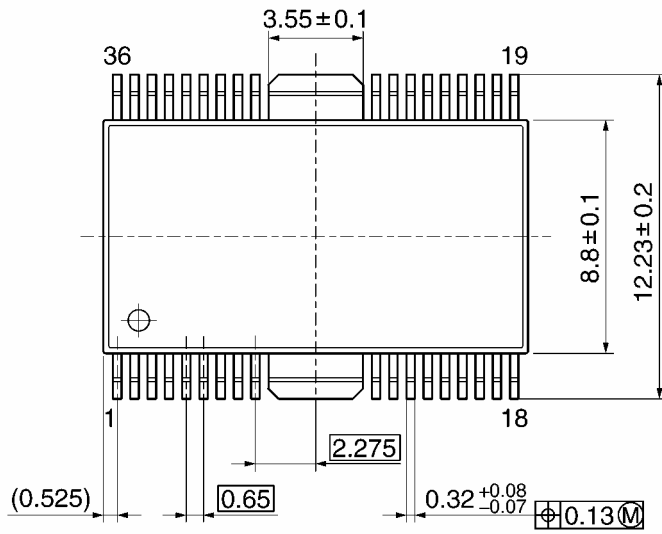

Weight: 0.79 g (typ.)

## Notes on Contents

### 1. Block Diagrams

Some of the functional blocks, circuits, or constants in the block diagram may be omitted or simplified for explanatory purposes.

### 2. Equivalent Circuits

The equivalent circuit diagrams may be simplified or some parts of them may be omitted for explanatory purposes.

### 3. Timing Charts

Timing charts may be simplified for explanatory purposes.

### 4. Application Circuits

The application circuits shown in this document are provided for reference purposes only. Thorough evaluation is required, especially at the mass production design stage.

Toshiba does not grant any license to any industrial property rights by providing these examples of application circuits.

### 5. Test Circuits

Components in the test circuits are used only to obtain and confirm the device characteristics. These components and circuits are not guaranteed to prevent malfunction or failure from occurring in the application equipment.

## IC Usage Considerations

### Notes on handling of ICs

- (1) The absolute maximum ratings of a semiconductor device are a set of ratings that must not be exceeded, even for a moment. Do not exceed any of these ratings.  
Exceeding the rating(s) may cause the device breakdown, damage or deterioration, and may result injury by explosion or combustion.
- (2) Use an appropriate power supply fuse to ensure that a large current does not continuously flow in case of over current and/or IC failure. The IC will fully break down when used under conditions that exceed its absolute maximum ratings, when the wiring is routed improperly or when an abnormal pulse noise occurs from the wiring or load, causing a large current to continuously flow and the breakdown can lead smoke or ignition. To minimize the effects of the flow of a large current in case of breakdown, appropriate settings, such as fuse capacity, fusing time and insertion circuit location, are required.
- (3) If your design includes an inductive load such as a motor coil, incorporate a protection circuit into the design to prevent device malfunction or breakdown caused by the current resulting from the inrush current at power ON or the negative current resulting from the back electromotive force at power OFF. IC breakdown may cause injury, smoke or ignition.  
Use a stable power supply with ICs with built-in protection functions. If the power supply is unstable, the protection function may not operate, causing IC breakdown. IC breakdown may cause injury, smoke or ignition.
- (4) Do not insert devices in the wrong orientation or incorrectly.  
Make sure that the positive and negative terminals of power supplies are connected properly. Otherwise, the current or power consumption may exceed the absolute maximum rating, and exceeding the rating(s) may cause the device breakdown, damage or deterioration, and may result injury by explosion or combustion.  
In addition, do not use any device that is applied the current with inserting in the wrong orientation or incorrectly even just one time.

**Points to Remember on Handling of ICs**

## (1) Over current protection circuit

Over current protection circuits (referred to as current limiter circuits) do not necessarily protect ICs under all circumstances. If the Over current protection circuits operate against the over current, clear the over current status immediately.

Depending on the method of use and usage conditions, such as exceeding absolute maximum ratings can cause the over current protection circuit to not operate properly or IC breakdown before operation. In addition, depending on the method of use and usage conditions, if over current continues to flow for a long time after operation, the IC may generate heat resulting in breakdown.

## (2) Thermal shutdown circuit

Thermal shutdown circuits do not necessarily protect ICs under all circumstances. If the thermal shutdown circuits operate against the over temperature, clear the heat generation status immediately. Depending on the method of use and usage conditions, such as exceeding absolute maximum ratings can cause the thermal shutdown circuit to not operate properly or IC breakdown before operation.

## (3) Heat radiation design

In using an IC with large current flow such as power amp, regulator or driver, please design the device so that heat is appropriately radiated, not to exceed the specified junction temperature (T<sub>J</sub>) at any time and condition. These ICs generate heat even during normal use. An inadequate IC heat radiation design can lead to decrease in IC life, deterioration of IC characteristics or IC breakdown. In addition, please design the device taking into consideration the effect of IC heat radiation with peripheral components.

## (4) Back-EMF

When a motor rotates in the reverse direction, stops or slows down abruptly, a current flow back to the motor's power supply due to the effect of back-EMF. If the current sink capability of the power supply is small, the device's motor power supply and output pins might be exposed to conditions beyond maximum ratings. To avoid this problem, take the effect of back-EMF into consideration in system design.

**RESTRICTIONS ON PRODUCT USE**

070122EBA\_R6

- The information contained herein is subject to change without notice. 021023\_D
- TOSHIBA is continually working to improve the quality and reliability of its products. Nevertheless, semiconductor devices in general can malfunction or fail due to their inherent electrical sensitivity and vulnerability to physical stress. It is the responsibility of the buyer, when utilizing TOSHIBA products, to comply with the standards of safety in making a safe design for the entire system, and to avoid situations in which a malfunction or failure of such TOSHIBA products could cause loss of human life, bodily injury or damage to property.  
In developing your designs, please ensure that TOSHIBA products are used within specified operating ranges as set forth in the most recent TOSHIBA products specifications. Also, please keep in mind the precautions and conditions set forth in the "Handling Guide for Semiconductor Devices," or "TOSHIBA Semiconductor Reliability Handbook" etc. 021023\_A
- The TOSHIBA products listed in this document are intended for usage in general electronics applications (computer, personal equipment, office equipment, measuring equipment, industrial robotics, domestic appliances, etc.). These TOSHIBA products are neither intended nor warranted for usage in equipment that requires extraordinarily high quality and/or reliability or a malfunction or failure of which may cause loss of human life or bodily injury ("Unintended Usage"). Unintended Usage include atomic energy control instruments, airplane or spaceship instruments, transportation instruments, traffic signal instruments, combustion control instruments, medical instruments, all types of safety devices, etc. Unintended Usage of TOSHIBA products listed in this document shall be made at the customer's own risk. 021023\_B
- The products described in this document shall not be used or embedded to any downstream products of which manufacture, use and/or sale are prohibited under any applicable laws and regulations. 060106\_Q
- The information contained herein is presented only as a guide for the applications of our products. No responsibility is assumed by TOSHIBA for any infringements of patents or other rights of the third parties which may result from its use. No license is granted by implication or otherwise under any patents or other rights of TOSHIBA or the third parties. 070122\_C
- Please use this product in compliance with all applicable laws and regulations that regulate the inclusion or use of controlled substances.  
Toshiba assumes no liability for damage or losses occurring as a result of noncompliance with applicable laws and regulations. 060819\_AF
- The products described in this document are subject to foreign exchange and foreign trade control laws. 060925\_E