

Preliminary TOSHIBA Bi-CMOS Integrated Circuit Silicon Monolithic

TB6561FG

Dual Full-Bridge Driver IC

The TB6561FG is a dual bridge driver IC for DC brush motor that contains MOS transistors in an output stage.

By using low ON-resistance MOS transistors and PWM current control circuitry, the driver achieves high efficiency.

Features

- Power supply voltage: 40 V (max)
- Output current: 1.5 A (max)
- Low ON-resistance: 1.5 Ω (upper and lower transistors/typ.)
- Direct PWM current control system
- Power-saving function
- Forward/reverse/short brake/stop modes
- Over-current protection: $I_{lim} = 2.5A$ (typ.)
- Thermal shutdown
- Package: SDIP-24-P-300-1.78

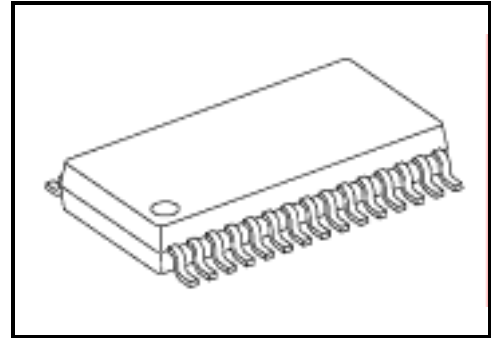

Weight: 0.63 g (typ.)

The TB6561FG is a Pb-free product.

The following conditions apply to solderability:

*Solderability

1. Use of Sn-63Pb solder bath
 - *solder bath temperature = 230°C
 - *dipping time = 5 seconds
 - *number of times = once
 - *use of R-type flux
2. Use of Sn-3.0Ag-0.5Cu solder bath
 - *solder bath temperature = 245°C
 - *dipping time = 5 seconds
 - *number of times = once
 - *use of R-type flux

Block Diagram

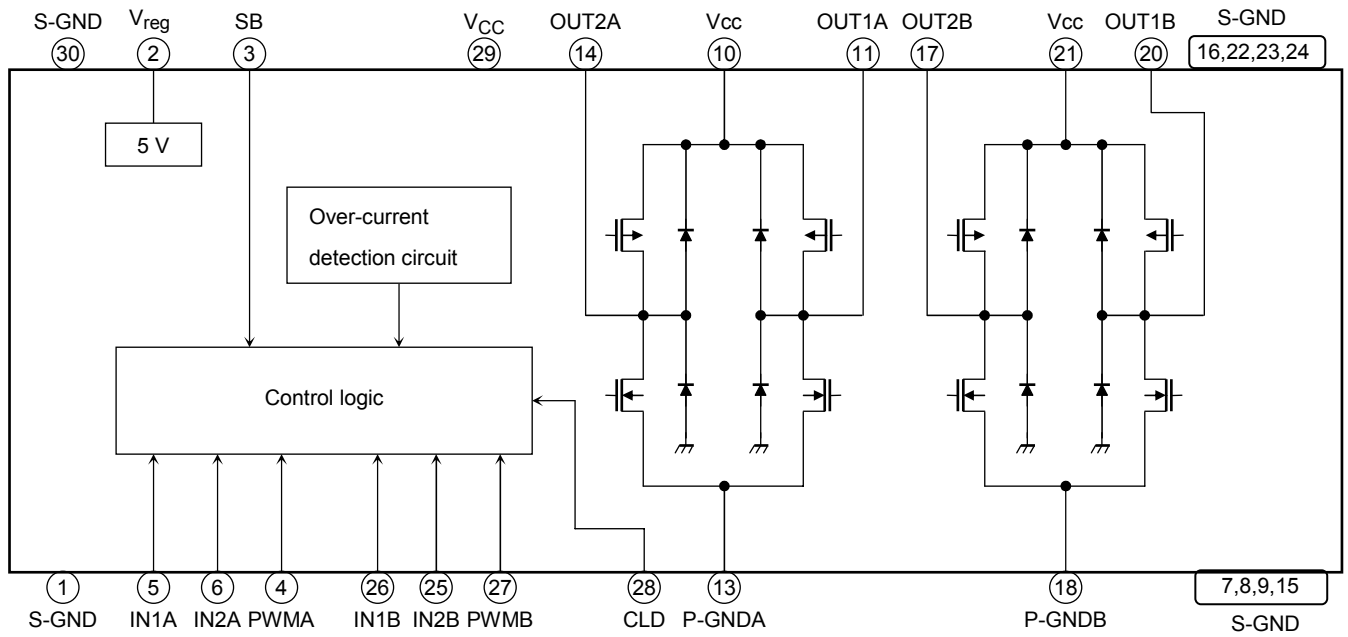

N.C.: 12pin, 19pin

Maximum Ratings (Ta = 25°C)

Characteristics	Symbol	Rating	Unit
Power supply voltage	V _{CC}	40	V
Output voltage	V _O	40 (Note 1)	V
Output current	I _O (Peak)	1.5	A
Power dissipation	P _D	(Note 2)	W
Operating temperature	T _{opr}	-20 to 85	°C
Storage temperature	T _{stg}	-55 to 150	°C

Note 1: Please use output voltage within the above maximum rating, 40 V, in which includes back-EMF voltage.

Note 2: When mounted on a board (50 mm × 50 mm × 1.6 mm, Cu area: 50%)

Operating Range (Ta = 25°C)

Characteristics	Symbol	Rating	Unit
Power supply voltage	V _{CC}	10 to 36	V

Pin Description

Pin No.	Symbol	Function Description	Remarks
1	S-GND	Signal ground	—
2	V _{reg}	5-V output pin	Connect a capacitor (0.1 μ F) between this pin and S-GND pin.
3	SB	Standby pin	High: Start, Low: Standby, Pull-down resistor
4	PWMA	Rotation direction control pin (chA)	Apply a 0-V/5-V signal. Pull-down resistor
5	IN1A	Input pin 1 (chA)	Apply a 0-V/5-V signal. Pull-down resistor
6	IN1B	Input pin 2 (chA)	Apply a 0-V/5-V signal. Pull-down resistor
7	S-GND	Signal ground	—
8	S-GND	Signal ground	—
9	S-GND	Signal ground	—
10	V _{cc}	Power supply voltage input pin for motor drive (chA)	V _{CC} (opr) = 10 V to 36 V
11	OUT1A	Output pin 1 (chA)	Connect to a motor coil pin.
12	N.C.	—	—
13	P-GNDA	Power ground for chA output	—
14	OUT2 A	Output pin 2 (chA)	Connect to a motor coil pin.
15	S-GND	Signal ground	—
16	S-GND	Signal ground	—
17	OUT2B	Output pin 2 (chB)	Connect to a motor coil pin.
18	P-GNDB	Power ground for chB output	—
19	N.C.	—	—
20	OUT1 B	Output pin 1 (chB)	Connect to a motor coil pin.
21	V _{cc}	Power supply voltage input pin for motor drive (chB)	V _{CC} (opr) = 10 V to 36 V
22	S-GND	Signal ground	—
23	S-GND	Signal ground	—
24	S-GND	Signal ground	—
25	IN2B	Input pin used to set output current level (chB)	Input 0-V/5-V signal. Pull-down resistor
26	IN1B	Input pin used to set output current level (chB)	Input 0-V/5-V signal. Pull-down resistor
27	PWM B	Rotation direction control pin (chB)	Input 0-V/5-V signal. Pull-down resistor
28	CLD	Output signal pin of current limiter detection	—
29	V _{CC}	Power supply voltage input pin	V _{CC} (opr) = 10 V to 36 V
30	S-GND	Signal ground	—

Electrical Characteristics (V_{CC} = 24 V, Ta = 25°C)

Characteristics		Symbol	Test Circuit	Test Condition	Min	Typ.	Max	Unit
Supply current		I _{CC1}	—	Stop mode	—	5.5	10	mA
		I _{CC2}		Forward/reverse mode	—	5.0	9	
		I _{CC3}		Short break mode	—	5.5	10	
		I _{CC4}		Standby mode	—	1.5	3	
Control circuit	Input voltage	V _{INH}	—	—	2.3	—	5.5	V
		V _{INL}		—	-0.2	—	0.8	
	Hysteresis voltage	V _{IN (HYS)}	—	(Design guarantee)	—	0.4	—	
	Input current	I _{INH}	—	V _{IN} = 5 V	30	50	75	μA
I _{INL}		V _{IN} = 0 V		—	—	5		
PWM input circuit	Input voltage	V _{PWMH}	—	—	2.3	—	5.5	V
		V _{PWML}		—	-0.2	—	0.8	
	Hysteresis voltage	V _{PWM (HYS)}	—	(Design guarantee)	—	0.4	—	
	Input current	I _{PWMH}	—	V _{PWM} = 5 V	30	50	75	μA
		I _{PWML}		V _{PWM} = 0 V	—	—	5	
	PWM frequency	f _{PWM}	—	Duty: 50 %	—	—	100	kHz
Minimum clock pulse width	t _{w(PWM)}	—	—	2.0	—	—	μs	
Standby circuit	Input voltage	V _{INSH}	—	—	2.3	—	5.5	V
		V _{INSL}		—	-0.2	—	0.8	
	Hysteresis voltage	V _{IN (HYS)}	—	(Design guarantee)	—	0.4	—	
	Input current	I _{INSH}	—	V _{IN} = 5 V	30	50	75	μA
I _{INSL}		V _{IN} = 0 V		—	—	5		
Output ON resistance		R _{on (U + L)}	—	I _o = 0.2 A	—	1.5	2.0	Ω
				I _o = 1.5 A	—	1.5	2.0	
Output leakage current		I _{L (U)}	—	V _{CC} = 40 V	—	—	10	μA
		I _{L (L)}		V _{CC} = 40 V	—	—	10	
Diode forward voltage		V _{F (U)}	—	I _o = 1.5 A	—	1.3	2.0	V
		V _{F (L)}		I _o = 1.5 A	—	1.3	2.0	
Internal reference voltage		V _{reg}	—	I _{reg} = 1 mA	4.75	5	5.25	V
Output signal of current limiter detection		V _{CLDH}	—	I _o = 50 μA	4.25	—	V _{reg}	V
		V _{CLDL}			—	—	0.5	
Offset time for current limiter		I _{SD (OFF)}	—	(Design guarantee)	—	50	—	μs
Thermal shutdown circuit operating temperature		T _{SD}	—	(Design guarantee)	—	160	—	°C

Input/Output Function

Input				Output		
IN1	IN2	SB	PWM	OUT1	OUT2	Mode
H	H	H	H	L	L	Short brake
			L			
L	H	H	H	L	H	CW/CCW
			L	L	L	Short brake
H	L	H	H	H	L	CCW/CW
			L	L	L	Short brake
L	L	H	H	OFF (high-impedance)		Stop
			L			
H/L	H/L	L	H	OFF (high-impedance)		Standby
			L			

Component Description

1. PWM control function

The IC enters CW (CCW) mode and short brake mode alternately in PWM current control.

To prevent shoot-through current caused by simultaneous conduction of upper and lower transistors in the output stage, a dead time is internally generated for 500 ns (target spec) when switching the upper and lower transistors.

Therefore, synchronous rectification for high efficiency in PWM current control can be achieved without an off-time that is generated via an external input.

Even when toggling between CW and CCW modes, and CW (CCW) and short brake modes, the off-time is not required due to the internally generated dead time.

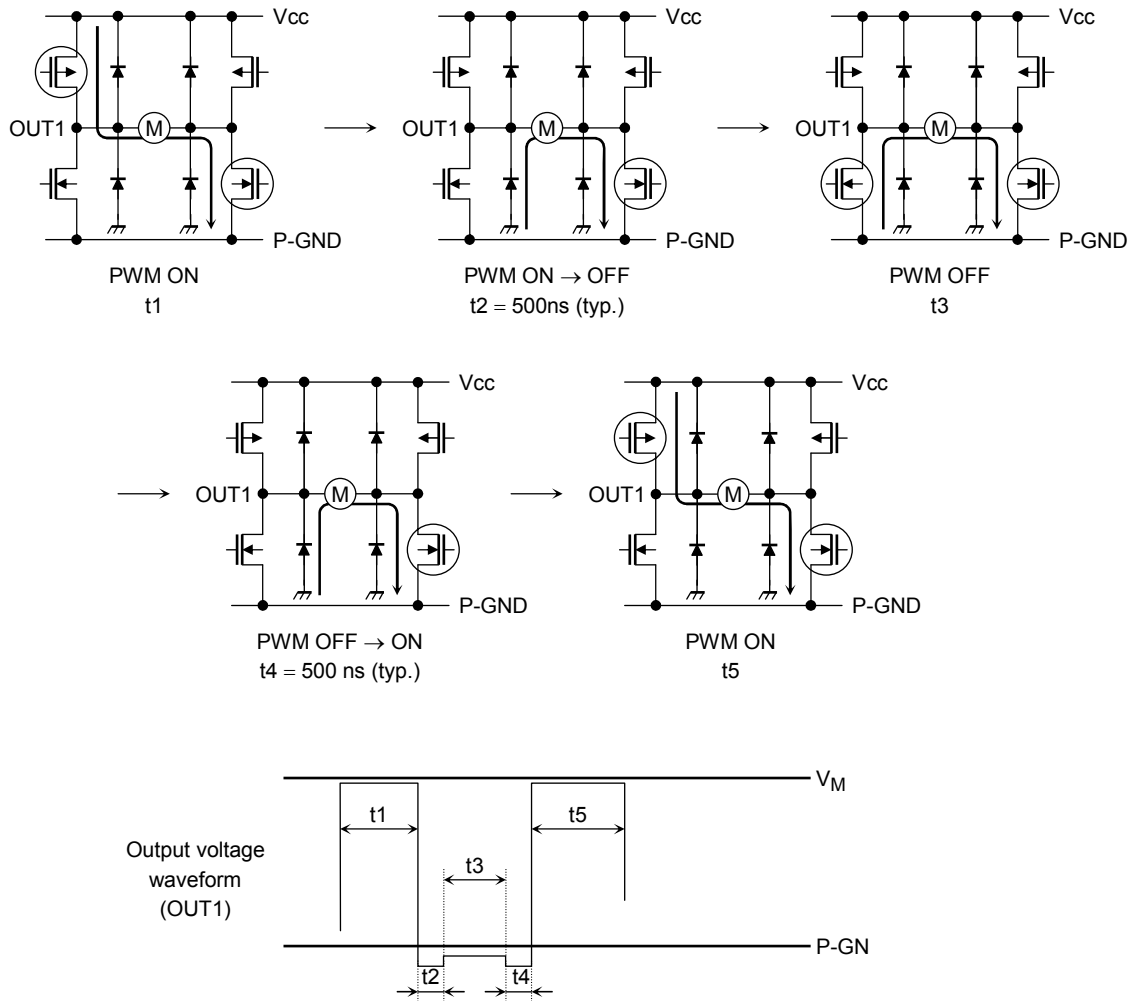

2. Thermal Shutdown Circuit (TSD)

The IC incorporates a thermal shutdown circuit. When the junction temperature (T_j) reaches 160°C (typ.), the output transistors are turned off.

After 50 μ s (typ.), the output transistors are turned on automatically.

The IC has 20°C of temperature hysteresis.

$T_{SD} = 160^\circ\text{C}$ (target spec)

$\Delta T_{SD} = 20^\circ\text{C}$ (target spec)

3. Overcurrent Protection Circuit (ISD)

The IC incorporates an overcurrent protection circuit to detect voltage that flows through the output transistors. The overcurrent threshold is 2.5 A (typ.).

Currents that flow through the output transistors are monitored individually. If overcurrent is detected in at least one of the transistors, all transistors are turned off.

The IC incorporates a timer to count 50 μ s (typ.) for which the transistors are off. After 50 μ s, they are turned on automatically. If an overcurrent occurs again, the same operation is repeated. To prevent false detection due to glitch, the circuit turns off the transistors only when current that exceeds the overcurrent threshold flows for 10 μ s or longer.

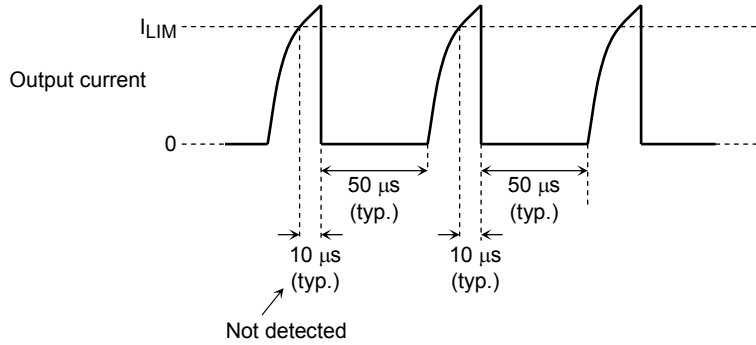

The over-current threshold is a target spec. It varies in a range from approximately 1.5 A to 3.5 A.

1. Current Limiter Detection Circuit (CLD)

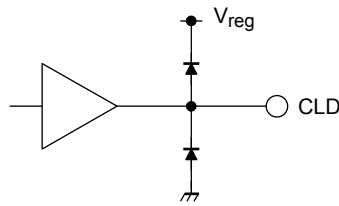

The CLD pin outputs the states of the current limiter and thermal shutdown circuits. If the current limiter for either channel A or B or the thermal shutdown circuit (shared for both channels) operates, the CLD pin state changes from low (normal state) to high.

The CLD circuit supports automatic recovery; its output returns to low once the current decreases to a value below the limit or once the thermal shutdown state is released.

Mode	CLD Output
Under TSD operation and current detection	H
Normal	L

< When current limiter operated >

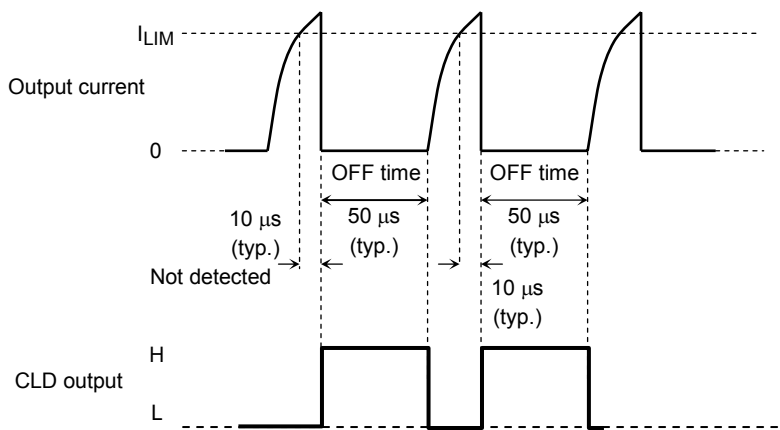

< When TSD circuit operated >

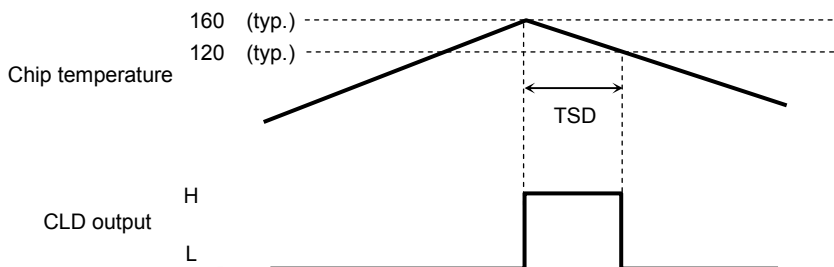

Current noise and other factors may cause false pulse output. To avoid this, Toshiba recommends a user to insert a filter or to carry out detection using a sampling monitor. When inserting a filter, please set the filter time-constant, considering the 50-μs CLD output.

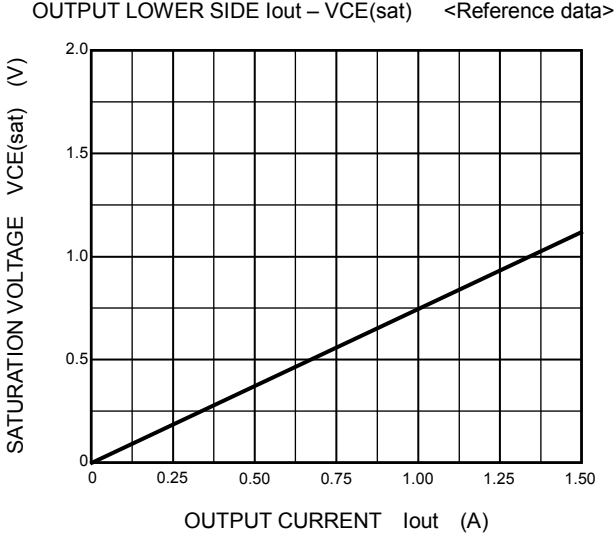
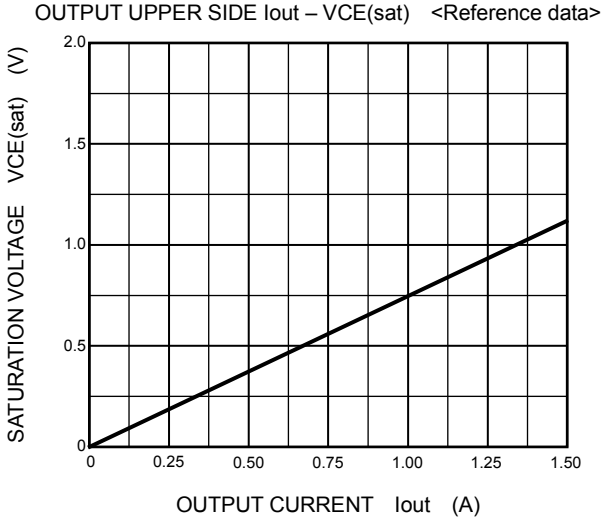

Application Circuit

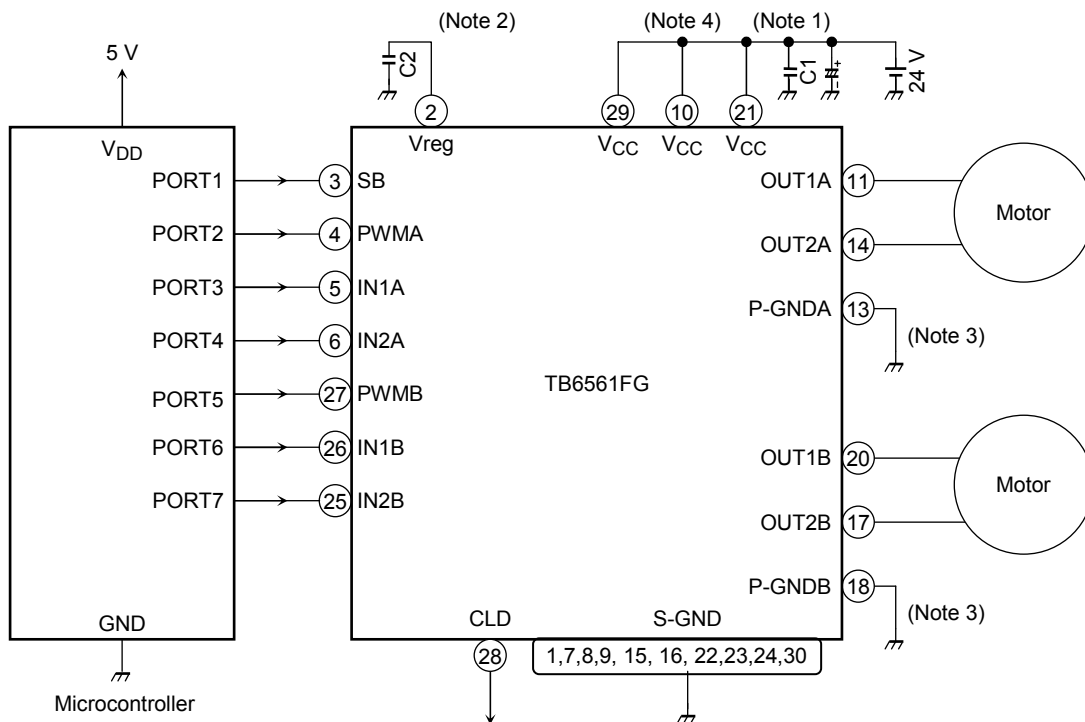

Note 1: A power supply capacitor should be connected between V_{CC} and P-GND as close as possible to the IC.

Note 2: C2(0.1 μ F) should be connected as close as possible to S-GND.

Note 3: Avoid connecting the resistor to detect the motor current. If necessary, connect the resistor to V_{CC} line.

Note 4: V_{CC} (10 pin, 21 pin, 29 pin) should be shorted externally.

Note 5: When the power is turned on, set SB for low (standby mode) or IN1 and IN2 for low (stop mode).

Caution for using

- The IC may be destroyed due to short circuit between output pins, an output pin and the V_{CC} pin, or an output pin and the ground pin.
Design an output line, V_{CC} line and ground line with great care.
- The IC may be destroyed when mounted in the wrong orientation. Thus, please mount it with great care.

Package Dimensions

SSOP30-P-375-1.00

Unit : mm

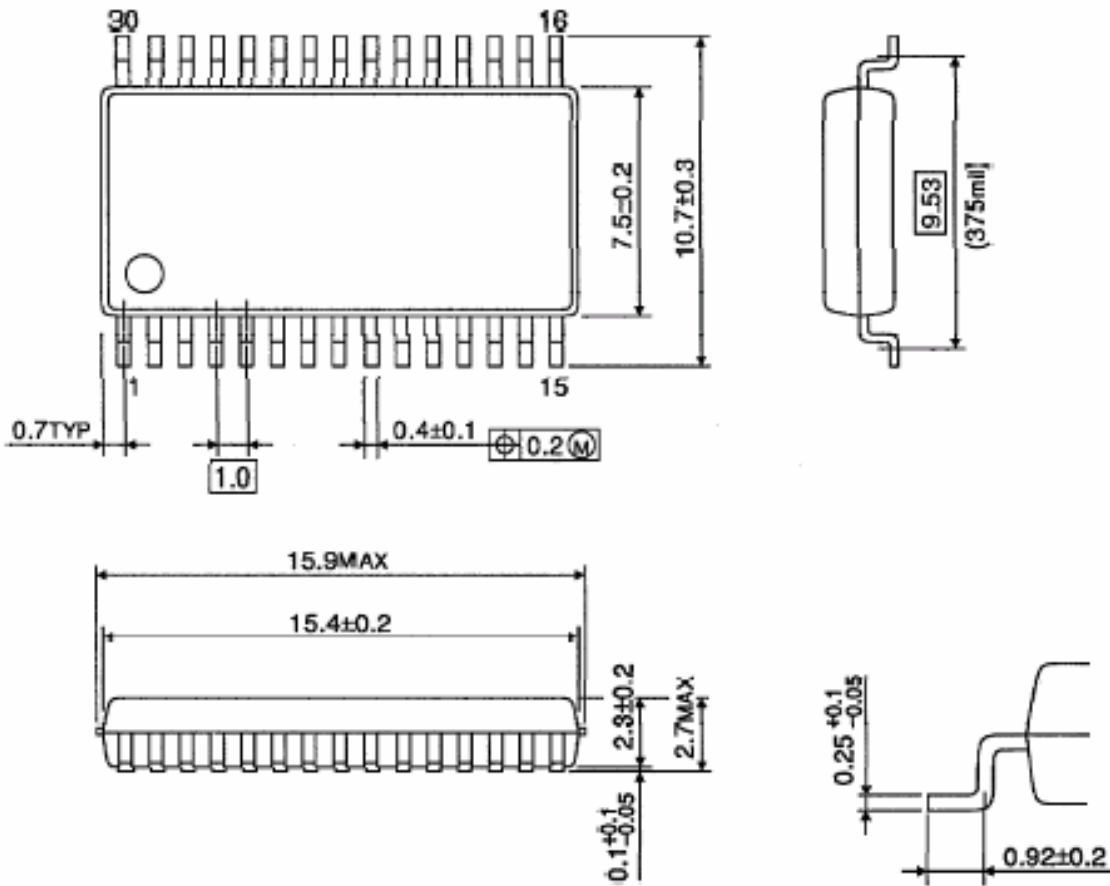

Weight: 0.63 g (typ.)

Notes on Contents

1. Block Diagrams

Some of the functional blocks, circuits, or constants in the block diagram may be omitted or simplified for explanatory purposes.

2. Equivalent Circuits

The equivalent circuit diagrams may be simplified or some parts of them may be omitted for explanatory purposes.

3. Timing Charts

Timing charts may be simplified for explanatory purposes.

4. Maximum Ratings

The absolute maximum ratings of a semiconductor device are a set of specified parameter values which must not be exceeded during operation, even for an instant.

If any of these ratings are exceeded during operation, the device electrical characteristics may be irreparably altered and the reliability and lifetime of the device can no longer be guaranteed.

Moreover, these operations with exceeded ratings may cause breakdown, damage and/or degradation to other equipment. Applications using the device should be designed so that each maximum rating will never be exceeded in any operating conditions.

Before using, creating and/or producing designs, refer to and comply with the precautions and conditions set forth in this document.

5. Application Circuits

The application circuits shown in this document are provided for reference purposes only. Thorough evaluation is required, especially at the mass production design stage.

Toshiba does not grant any license to any industrial property rights by providing these examples of application circuits.

6. Test Circuits

Components in the test circuits are used only to obtain and confirm the device characteristics. These components and circuits are not guaranteed to prevent malfunction or failure from occurring in the application equipment.

About the handling of ICs

Install the product correctly to avoid breakdown, damage and/or degradation to the product or equipment.

About overcurrent protection and heat protection circuits

These protection functions are intended to guard against certain output short circuits or other abnormal conditions with only temporary effect, and are not guaranteed to prevent the IC from being damaged.

- These protection features may not be effective if the product is operated outside the guaranteed operating ranges, and some output short circuits may result in the IC being damaged.

The overcurrent protection feature is only intended to protect the IC from a temporary short circuit.

Short circuits of longer duration may damage the IC through undue stress. The systems must be configured so that any overcurrent condition will be eliminated as soon as possible.

Counter-electromotive force

When the motor reverses or stops, counter-electromotive force in the motor may influence the current to flow to the power source. If the power source lacks sink capability, the IC power and output pins may exceed the rating. The counter-electromotive force of the motor varies depending on the conditions of use and the features of the motor.

Therefore ensure that there is no damage to the IC or problem in operation, and no error in or damage to peripheral circuits resulting from counter-electromotive force.

RESTRICTIONS ON PRODUCT USE

030619EBA

- The information contained herein is subject to change without notice.
- The information contained herein is presented only as a guide for the applications of our products. No responsibility is assumed by TOSHIBA for any infringements of patents or other rights of the third parties which may result from its use. No license is granted by implication or otherwise under any patent or patent rights of TOSHIBA or others.
- TOSHIBA is continually working to improve the quality and reliability of its products. Nevertheless, semiconductor devices in general can malfunction or fail due to their inherent electrical sensitivity and vulnerability to physical stress. It is the responsibility of the buyer, when utilizing TOSHIBA products, to comply with the standards of safety in making a safe design for the entire system, and to avoid situations in which a malfunction or failure of such TOSHIBA products could cause loss of human life, bodily injury or damage to property.
In developing your designs, please ensure that TOSHIBA products are used within specified operating ranges as set forth in the most recent TOSHIBA products specifications. Also, please keep in mind the precautions and conditions set forth in the "Handling Guide for Semiconductor Devices," or "TOSHIBA Semiconductor Reliability Handbook" etc..
- The TOSHIBA products listed in this document are intended for usage in general electronics applications (computer, personal equipment, office equipment, measuring equipment, industrial robotics, domestic appliances, etc.). These TOSHIBA products are neither intended nor warranted for usage in equipment that requires extraordinarily high quality and/or reliability or a malfunction or failure of which may cause loss of human life or bodily injury ("Unintended Usage"). Unintended Usage include atomic energy control instruments, airplane or spaceship instruments, transportation instruments, traffic signal instruments, combustion control instruments, medical instruments, all types of safety devices, etc.. Unintended Usage of TOSHIBA products listed in this document shall be made at the customer's own risk.
- The products described in this document are subject to the foreign exchange and foreign trade laws.
- TOSHIBA products should not be embedded to the downstream products which are prohibited to be produced and sold, under any law and regulations.