

TOSHIBA Bi-CMOS Integrated Circuit Silicon Monolithic

TB6556F

3-Phase Full-Wave Sine-Wave PWM Brushless Motor Controller

Features

- Sine-wave PWM control
- Built-in triangular-wave generator
(carrier cycle = $f_{osc}/252$ (Hz))
- Built-in lead angle control function (0° to 58° in 32 steps)
External setting/Automatic internal setting
- Built-in dead time function (setting 2.6 μ s or 3.8 μ s)
- Supports bootstrap circuit
- Overcurrent protection signal input pin
- Built-in regulator ($V_{refout} = 5$ V (typ.), 30 mA (max))
- Operating supply voltage range: $V_{CC} = 6$ V to 10 V

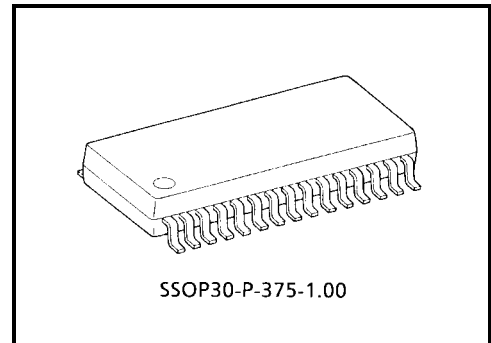

Weight: 0.33 g (typ.)

Block Diagram

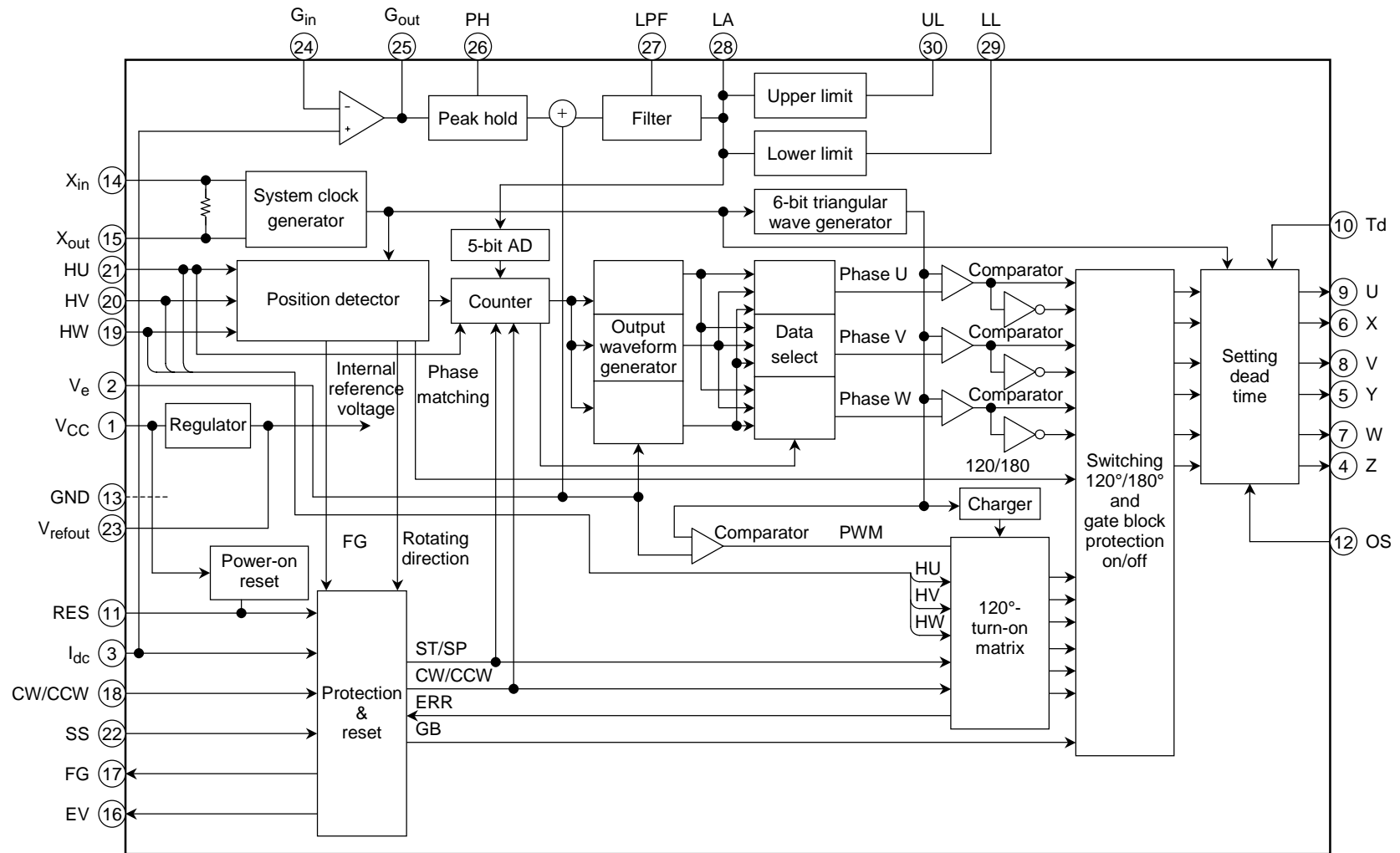

Pin Description

Pin No.	Symbol	Description	Remarks
21	HU	Positional signal input pin U	When positional signal is HHH or LLL, gate block protection operates. With built-in pull-up resistor Built-in digital filter (≈ 500 ns)
20	HV	Positional signal input pin V	
19	HW	Positional signal input pin W	
18	CW/CCW	Rotation direction signal input pin	L: Forward H: Reverse
11	RES	Reset-signal-input pin	L: Reset (Output is non-active) Operation/Halt operation, Also used for gate protection, built-in pull-up resistor
2	V_e	Voltage command signal	With built-in pull-down resistor
24	G_{in}	Gain setting	Gain I_{dc} signal level, which is to meet the LA to be the best angle.
25	G_{out}		
26	PH	Peak hold	Connect peak-hold capacitor and discharge resistor to GND, parallel to each other
27	LPF	RC low-pass filter	Connect capacitor for low-pass filter (built-in 100 k Ω resistor)
28	LA	Lead angle setting signal input pin	Sets 0° to 58° in 32 steps
29	LL	Lower limit for LA	Set lower limit for LA (LL = 0 V to 5.0 V)
30	UL	Upper limit for LA	Set upper limit for LA (UL = 0 V to 5.0 V)
12	OS	Inputs output logic select signal	L: Active low H: Active high
3	I_{dc}	Inputs overcurrent-protection-signal	Inputs DC link current. Reference voltage: 0.5 V With built-in filter (≈ 1 μ s) Built-in digital filter (≈ 1 μ s)
14	X_{in}	Inputs clock signal	With built-in feedback resistor
15	X_{out}	Outputs clock signal	
23	V_{refout}	Outputs reference voltage signal	5 V (typ.), 30 mA (max)
17	FG	FG signal output pin	Outputs 3PPR of positional signal
16	REV	Reverse rotation detection signal	Detects reverse rotation.
9	U	Outputs turn-on signal	Select active high or active low using the output logic select pin.
8	V	Outputs turn-on signal	
7	W	Outputs turn-on signal	
6	X	Outputs turn-on signal	
5	Y	Outputs turn-on signal	
4	Z	Outputs turn-on signal	
1	V_{CC}	Power supply voltage pin	$V_{CC} = 6$ to 10 V
10	T_d	Inputs setting dead time	L: 3.8 μ s, H or OPEN: 1.9 μ s
22	SS	120°/180° select signal	L: 120° turn-on mode, H or OPEN: 180° turn-on mode
13	GND	Ground pin	—

Input/Output Equivalent Circuits

Pin Description	Symbol	Input/Output Signal	Input/Output Internal Circuit
Positional signal input pin U Positional signal input pin V Positional signal input pin W	HU HV HW	Digital With Schmitt trigger Hysteresis 300 mV (typ.) Digital filter: 500 ns (typ.) L: 0.8 V (max) H: $V_{refout} - 1$ V (min)	
Forward/reverse switching input pin L: Forward (CW) H: Reverse (CCW)	CW/CCW	Digital L: 0.8 V (max) H: $V_{refout} - 1$ V (min)	
Reset input L: Stops operation (reset). H: Operates.	RES	Digital L: 0.8 V (max) H: $V_{refout} - 1$ V (min)	
120°/180° select signal L: 120° turn-on mode H: 180° turn-on mode (Open)	SS	Digital With Schmitt trigger Hysteresis: 300 mV (typ.) L: 0.8 V (max) H: $V_{refout} - 1$ V (min)	
Voltage command signal 1.0 V < V_e ≤ 2.1 V Refresh operation (X, Y, Z pins: On duty of 8%)	V_e	Analog Input voltage range 0 to 5.4 V Input voltage of 5.4 V or higher is clipped to 5.4 V.	

Pin Description	Symbol	Input/Output Signal	Input/Output Internal Circuit
<p>Lead angle setting signal input pin</p> <p>0 V: 0° 5 V: 58° (5-bit AD)</p>	LA	<p>When LA is fixed externally, connect LL to GND and UL to V_{refout}, and then input setting voltage to LA pin.</p> <p>Input voltage range: 0 V to 5.0 V (V_{refout})</p> <p>Input voltage of V_{refout} or higher is clipped to V_{refout}.</p> <p>When LA is fixed automatically, open LA pin. At this condition, LA pin is used for only confirmation for LA width.</p>	
<p>Gain setting signal input (LA setting)</p>	<p>G_{in} G_{out}</p>	<p>Non-inverted amplifier 25 dB (max) G_{out} output voltage Low: GND High: $V_{CC} - 1.7$ V</p>	
<p>Peak hold (LA setting)</p>	PH	<p>Connect peak-hold capacitor and discharge resistor to GND, parallel to each other 100 kΩ/0.1 μF recommended</p>	
<p>Low-pass filter (LA setting)</p>	LPF	<p>Connect capacitor for low-pass filter (built-in 100 kΩ resistor) 0.1 μF recommended</p>	
<p>Lower limit for LA</p>	LL	<p>Clip lower limit for LA LL = 0 V to 5.0 V When LL > UL, LA is fixed at LL value.</p>	

Pin Description	Symbol	Input/Output Signal	Input/Output Internal Circuit
Upper limit for LA	UL	Clip upper limit for LA UL = 0V to 5.0 V When LL > UL, LA is fixed at LL value.	
Setting dead time input pin L: 3.8 μs H or Open: 1.9 μs	Td	Digital L: 0.8 V (max) H: V _{refout} - 1 V (min)	
Output logic select signal input pin L: Active low H: Active high	OS	Digital L: 0.8 V (max) H: V _{refout} - 1 V (min)	
Overcurrent protection signal input pin	I _{dc}	Analog Digital filter: 1 μs (typ.) Gate protected at 0.5 V or higher (released at carrier cycle)	
Clock signal input pin	X _{in}	Operating range 2 MHz to 8 MHz (crystal oscillation)	
Clock signal output pin	X _{out}		

Pin Description	Symbol	Input/Output Signal	Input/Output Internal Circuit
Reference voltage signal output pin	V_{refout}	$5 \pm 0.5 \text{ V}$ (max 30 mA)	
Reverse-rotation-detection signal output pin	REV	Digital Push-pull output: $\pm 1 \text{ mA}$ (max)	
FG signal output pin	FG	Digital Push-pull output: $\pm 1 \text{ mA}$ (max)	
Turn-on signal output pin U Turn-on signal output pin V Turn-on signal output pin W Turn-on signal output pin X Turn-on signal output pin Y Turn-on signal output pin Z	U V W X Y Z	Analog Push-pull output: $\pm 2 \text{ mA}$ (max) L: 0.78 V (max) H: $V_{refout} - 0.78 \text{ V}$ (min)	

Maximum Ratings (Ta = 25°C)

Characteristics	Symbol	Rating	Unit
Supply voltage	V _{CC}	12	V
Input voltage	V _{in} (1)	-0.3~V _{CC} (Note 1)	V
	V _{in} (2)	-0.3~V _{refout} + 0.3 (Note 2)	
Turn-on signal output current	I _{OUT}	2	mA
Power Dissipation	P _D	1.50 (Note 3)	W
Operating temperature	T _{opr}	-30~115 (Note 4)	°C
Storage temperature	T _{stg}	-50~150	°C

Note 1: V_{in} (1) pin: V_e, LA, G_{in}, G_{out}, PH, LPF, LL, UL

Note 2: V_{in} (2) pin: HU, HV, HW, CW/CCW, RES, OS, I_{dc}, Td, SS

Note 3: When mounted on PCB (universal 50 × 50 × 1.6 mm, Cu 30%)

Note 4: Operating temperature range is determined by the P_D – Ta characteristic.

Recommended Operating Conditions (Ta = 25°C)

Characteristics	Symbol	Min	Typ.	Max	Unit
Supply voltage	V _{CC}	6	7	10	V
Crystal oscillation frequency	X _{in}	2	4	8	MHz

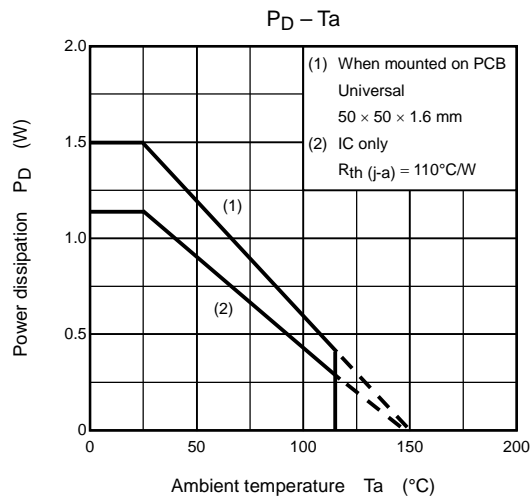

Electrical Characteristics (Ta = 25°C, VCC = 7 V)

Characteristics	Symbol	Test Circuit	Test Condition	Min	Typ.	Max	Unit	
Supply current	I _{CC}	—	V _{refout} = open	—	5	8	mA	
Input current	I _{in} (1)-1	—	V _{in} = 5 V LA	—	25	50	μA	
	I _{in} (1)-2		V _{in} = 5 V V _e	—	35	70		
	I _{in} (2)-1		V _{in} = 0 V HU, HV, HW, SS	-50	-25	—		
	I _{in} (2)-2		V _{in} = 0 V CW/CCW, OS, Td, RES	-100	-50	—		
Input voltage	V _{in}	High	HU, HV, HW, CW/CCW, RES, OS, Td, SS	V _{refout} - 1	—	V _{refout}	V	
		Low		—	—	0.8		
	V _e	H	—	PWM Duty 100%	5.1	5.4	5.7	V
		M		Refresh → Start motor operation	1.8	2.1	2.4	
L		Turned-off → Refresh		0.7	1.0	1.3		
Input hysteresis voltage	V _H	—	HU, HV, HW, SS (Note 5)	—	0.3	—	V	
Input delay time	V _{DT}	—	HU, HV, HW X _{in} = 4.19 MHz	—	0.5	—	μs	
	V _{DC}		I _{dc} X _{in} = 4.19 MHz	—	1.0	—		
Output voltage	V _{OUT} (H)-1	—	I _{OUT} = 2 mA U, V, W, X, Y, Z	V _{refout} - 0.78	V _{refout} - 0.3	—	V	
	V _{OUT} (L)-1		I _{OUT} = -2 mA U, V, W, X, Y, Z	—	0.3	0.78		
	V _{REV} (H)		I _{OUT} = 1 mA REV	V _{refout} - 1.0	V _{refout} - 0.2	—		
	V _{REV} (L)		I _{OUT} = -1 mA REV	—	0.2	1.0		
	V _{FG} (H)		I _{OUT} = 1 mA FG	V _{refout} - 1.0	V _{refout} - 0.2	—		
	V _{FG} (L)		I _{OUT} = -1 mA FG	—	0.2	1.0		
	V _{refout}		I _{OUT} = 30 mA V _{refout}	4.5	5.0	5.5		
Output leakage current	I _L (H)	—	V _{OUT} = 0 V U, V, W, X, Y, Z	—	0	10	μA	
	I _L (L)		V _{OUT} = 3.5 V U, V, W, X, Y, Z	—	0	10		
Output off-time by upper/lower transistor (Note 6)	T _{OFF} (H)	—	Td = High or open, X _{in} = 4.19 MHz, I _{OUT} = ± 2 mA, OS = High/Low	1.5	1.9	—	μs	
	T _{OFF} (L)		Td = Low, X _{in} = 4.19 MHz, I _{OUT} = ± 2 mA, OS = High/Low	3.0	3.8	—		
Overcurrent detection	V _{dc}	—	I _{dc}	0.46	0.5	0.54	V	
LA gain setting amp	AMP _{OUT}	—	G _{OUT} output current	5	—	—	mA	
	AMP _{OFS}		G _{IN} , G _{OUT} 11 kΩ/1 kΩ	—	-40	—		
LA limit setting difference	ΔL	—	LL = 0.7 V	-20	—	20	mV	
	ΔU		UL = 2.0 V	-20	—	20		
LA peak hold output current	PH _{OUT}	—	PH output current	—	—	5	mA	
Lead angle correction	T _{LA} (0)	—	LA = 0 V or Open, Hall IN = 100 Hz	—	0	—	°	
	T _{LA} (2.5)		LA = 2.5 V, Hall IN = 100 Hz	27.5	32	34.5		
	T _{LA} (5)		LA = 5 V, Hall IN = 100 Hz	53.5	59	62.5		
V _{CC} monitor	V _{CC} (H)	—	Output start operation point	4.2	4.5	4.8	V	
	V _{CC} (L)		No output operation point	3.7	4.0	4.3		
	V _H		Input hysteresis width	—	0.5	—		

Note 5: Toshiba doesn't implement a test before shipping.

Note 6: T_{OFF}

OS = High

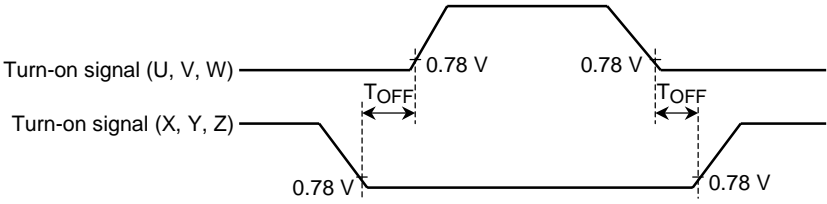

OS = Low

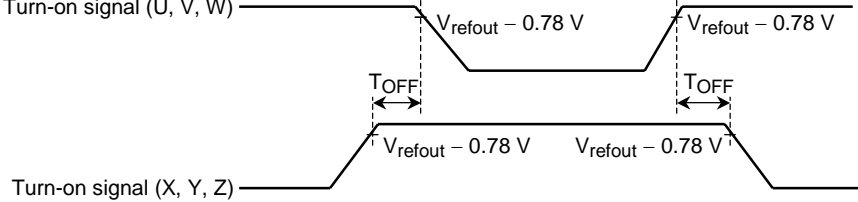

Functional Description

1. Basic operation

The motor is driven by the square-wave turn-on signal based on a positional signal. When the positional signal reaches number of rotations $f = 5$ Hz or higher, the rotor position is assumed according to the positional signal and a modulation wave is generated. The modulation wave and the triangular wave are compared then the sine-wave PWM signal is generated and the motor is driven.

From start to 5 Hz: When driven by square wave (120° turn-on) $f = f_{osc}/(2^{12} \times 32 \times 6)$

5 Hz~: When driven by sine-wave PWM (180° turn-on) When $f_{osc} = 4$ MHz, approx. 5 Hz

2. Select drive function

This function can select drive mode.

SS pin

High or OPEN = Sine-wave PWM drive (180° turn-on mode)

Low = Square-wave drive (120° turn-on mode)

Note: If the position sensing signal is $f = 5$ Hz or lower, the driver is 120° turn-on mode even when SS = High.

3. V_e voltage command signal function and function to stabilize bootstrap voltage

(1) When voltage command signal is input at $V_e \leq 1.0$ V:

Turns off output (gate protection)

(2) When voltage command signal is input at 1.0 V < $V_e \leq 2.1$ V:

Turns on the lower transistor at regular (carrier) cycle. (On duty is approx. 8%)

(3) When voltage command signal is input at $V_e > 2.1$ V:

During sin-wave drive, outputs drive signal as it is. During square-drive, forcibly turns on the lower transistor at regular (carrier) cycle. (On duty is approx. 8%)

Note: At startup, to charge the upper transistor gate power supply, turn the lower transistor on for a fixed time with 1.0 V < $V_e \leq 2.1$ V.

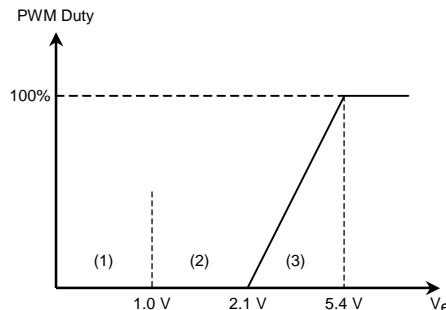

4. Dead time function: upper/lower transistor output off-time

When driving the motor by sine-wave PWM, to prevent a short circuit caused by simultaneously turning on upper and lower external power devices, digitally generates dead time in the IC.

When a square wave is generated in full duty cycle mode, the dead time function is turned on to prevent a short circuit.

Td Pin	Internal Counter	T _{OFF}
High or Open	8/f _{osc}	1.9 μs
Low	16/f _{osc}	3.8 μs

T_{OFF} values above are obtained when $f_{osc} = 4.19$ MHz.

f_{osc} = reference clock (crystal oscillation)

5. Correcting lead angle

The lead angle can be corrected in the turn-on signal range from 0 to 58° in relation to the induced voltage.

Analog input from LA pin (0 V to 5 V divided by 32)

0 V = 0°

5 V = 58° (when more than 5 V is input, 58°)

6. Setting carrier frequency

Sets triangular wave cycle (carrier cycle) necessary for generating PWM signal.

(The triangular wave is used for forcibly turning on the lower transistor when driving the motor by square wave.)

Carrier cycle = $f_{osc}/252$ (Hz) f_{osc} = Reference clock (crystal oscillation)

7. Switching the output of turn-on signal

Switches the output of turn-on signal between high and low.

Pin OS:

High = active high

Low = active low

8. Outputting reverse rotation detection signal

Detects motor rotation direction every electrical degrees of 360°. (The output is high immediately after reset)

REV terminal increases with a 180° turn-on mode at the time of low.

CW/CCW Pin	Actual Motor Rotating Direction	REV Pin
Low (CW)	CW (forward)	Low
	CCW (reverse)	High
High (CCW)	CW (forward)	High
	CCW (reverse)	Low

9. Protecting input pin

1. Overcurrent protection (Pin I_{dc})

When the DC-link-current exceeds the internal reference voltage, performs gate block protection.

Overcurrent protection is released for each carrier frequency.

Reference voltage = 0.5 V (typ.)

2. Gate protection (Pin RES)

When the input signal level is Low, turns off the output; when High, restarts the output.

Detects abnormality externally and inputs the signal to the pin RES.

RES Pin	OS Pin	Output Turn-on Signal (U, V, W, X, Y, Z)
Low	Low	High
	High	Low

(When RES = Low, bootstrap capacitor charging stops.)

3. Internal protection

- Positional signal abnormality protection

When the positional signal is HHH or LLL, turns off the output; otherwise, restarts the output.

- Low power supply voltage protection (VCC monitor)

When power supply is on/off, prevents damage caused by short-circuiting power device by keeping the turn-on signal output at high impedance outside the operating voltage range. However, if voltage level is supplied from V_e pin, this function is restricted. E.g. when $V_e > 4.9\text{ V}$ is applied, low power supply voltage protection isn't operated.

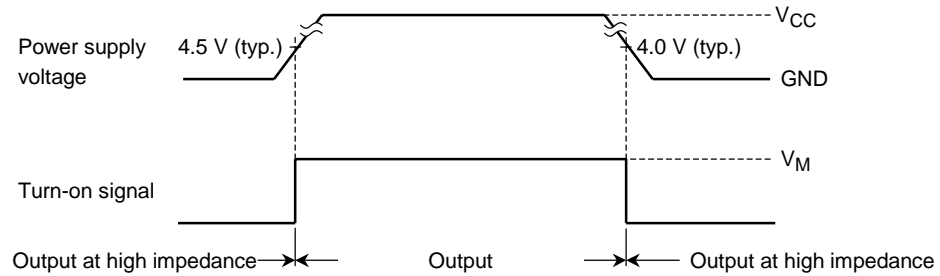

Operation Flow

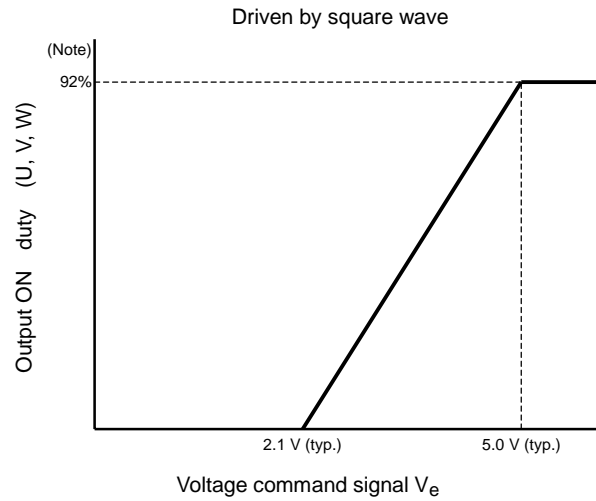
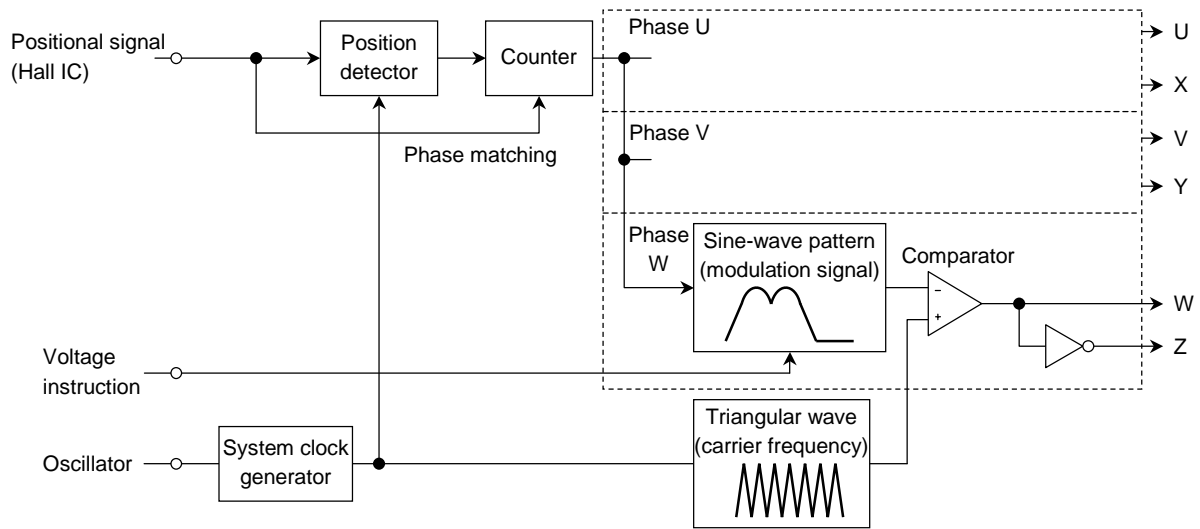

Note: Output ON time is decreased by the dead time.
 (carrier frequency \times 92% $- T_d \times 2$)

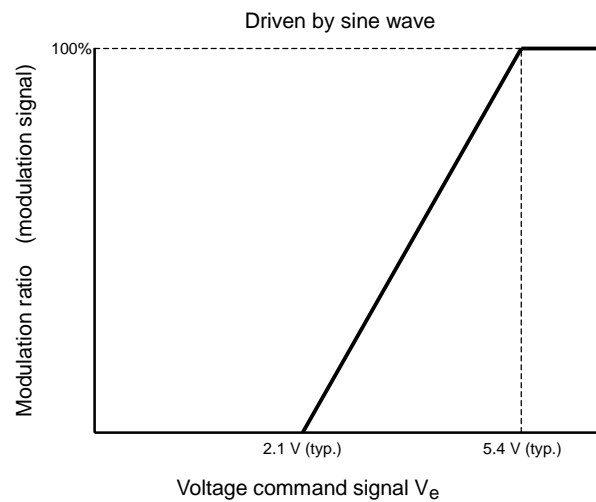

The modulation waveform is generated using Hall signals. Then, the modulation waveform is compared with the triangular wave and a sine-wave PWM signal is generated.

The time (electrical degrees: 60°) from the rising (or falling) edges of the three Hall signals to the next falling (or rising) edges are counted. The counted time is used as the data for the next 60° phase of the modulation waveform.

There are 32 items of data for the 60° phase of the modulation waveform. The time width of one data item is 1/32 of the time width of the 60° phase of the previous modulation waveform. The modulation waveform moves forward by the width.

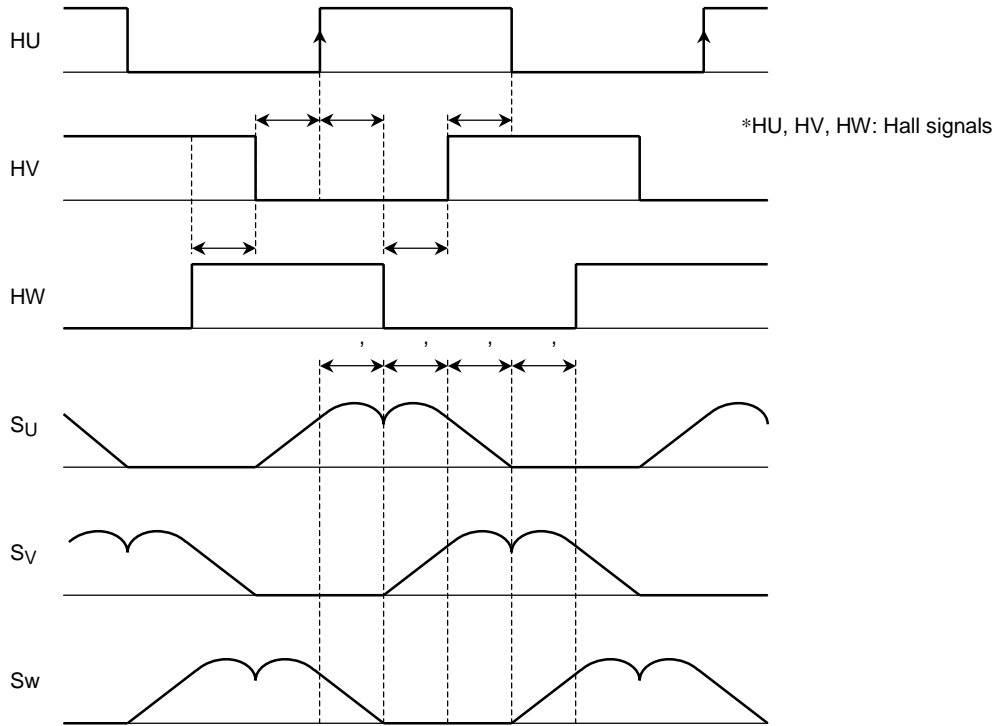

In the above diagram, the modulation waveform (1)' data moves forward by the 1/32 time width of the time (1) from HU: ↑ to HW: ↓. Similarly, data (2)' moves forward by the 1/32 time width of the time (2) from HW: ↓ to HV: ↑.

If the next edge does not occur after the 32 data items end, the next 32 data items move forward by the same time width until the next edge occurs.

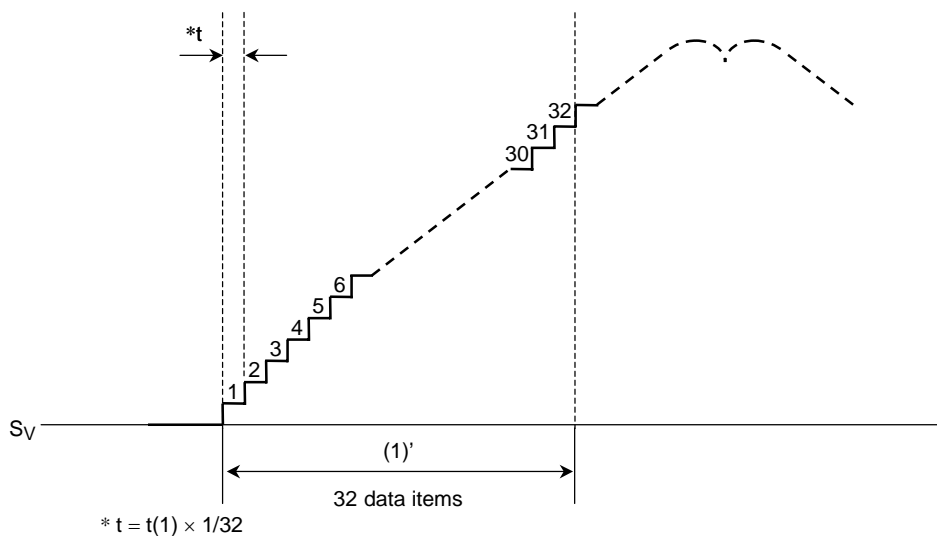

The modulation wave is brought into phase with every zero-cross point of the Hall signal.

The modulation wave is reset in synchronization with the rising and falling edges of the Hall signal at every 60° electrical degrees. Thus, when the Hall device is not placed at the correct position or when accelerating/decelerating, the modulation waveform is not continuous at every reset.

Timing Charts

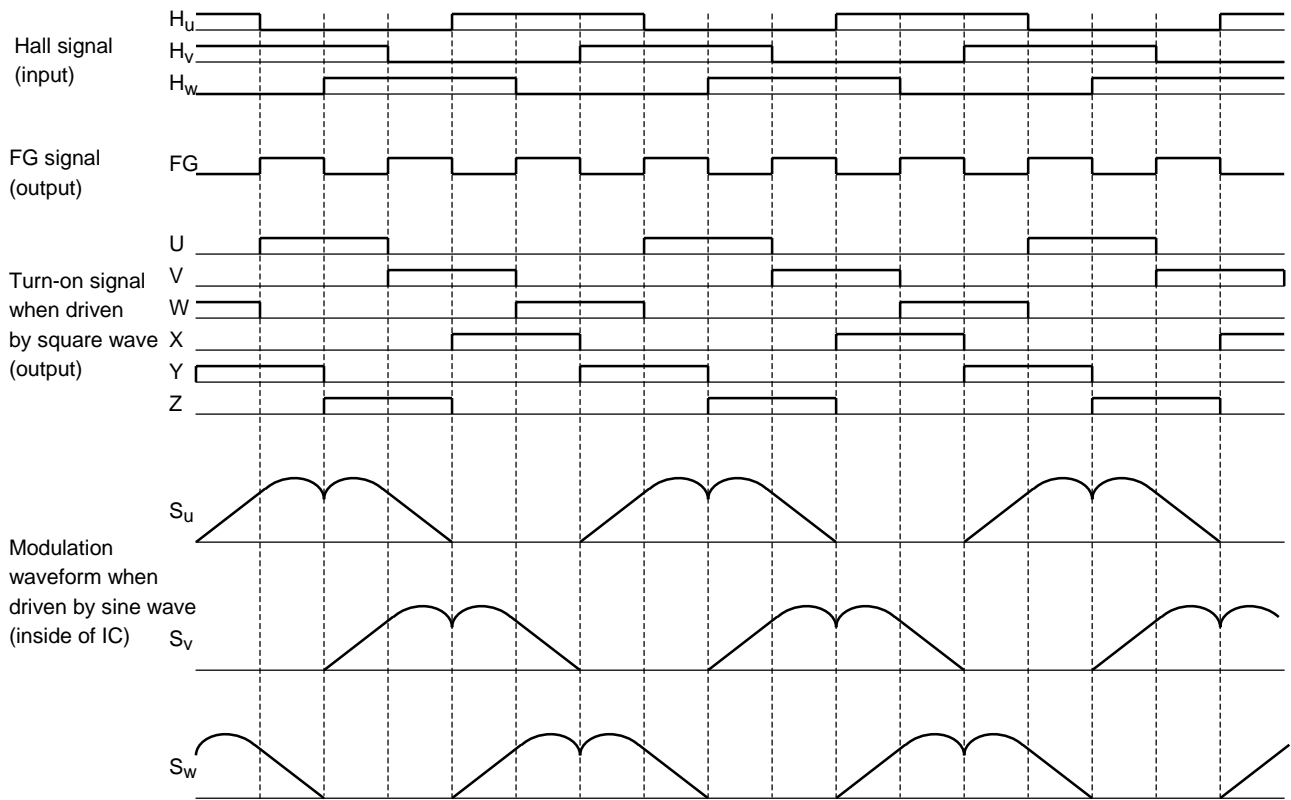

Forward

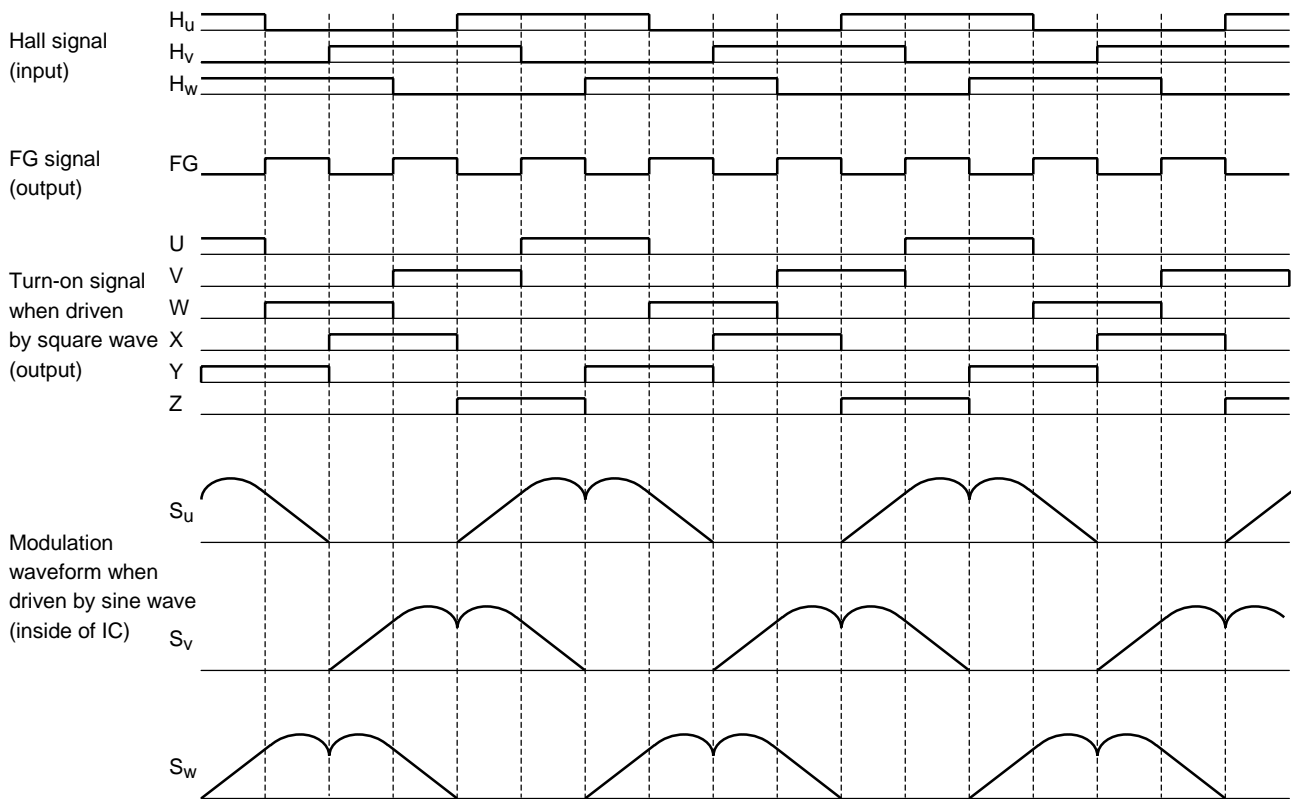

Reverse

Operating Waveform When Driven by Square Wave (CW/CCW = Low, OS = High)

Hall signal

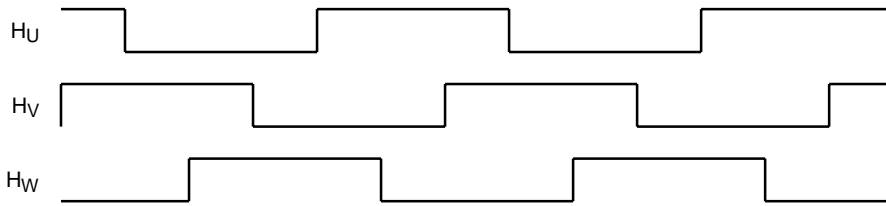

Output waveform

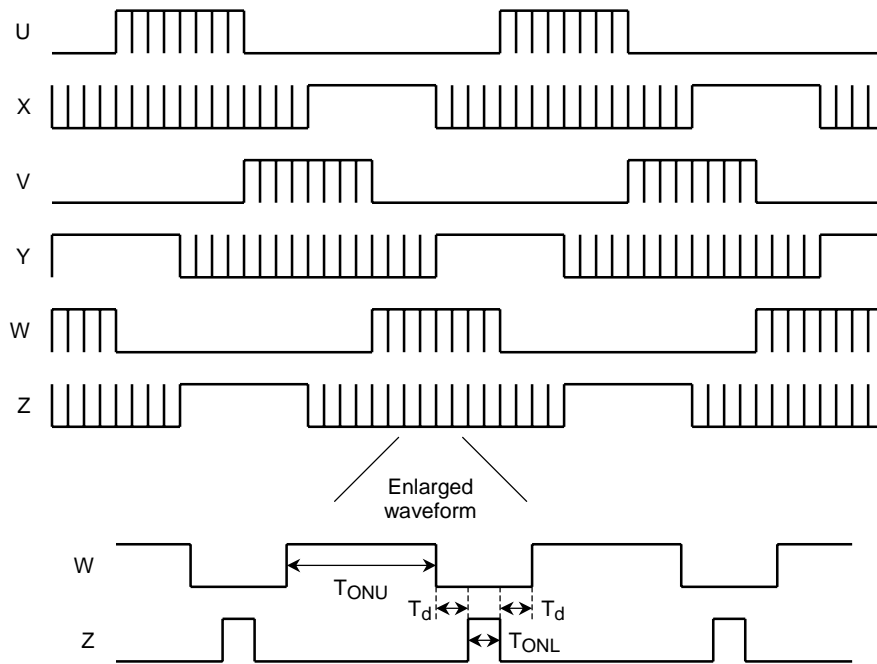

To stabilize the bootstrap voltage, the lower outputs (X, Y, and Z) are always turned on at the carrier cycle even during off time. At that time, the upper outputs (U, V, and W) are assigned dead time and turned off at the timing when the lower outputs are turned on. (T_d varies with input V_e)

$$\text{Carrier cycle} = f_{osc}/252 \text{ (Hz)}$$

$$\text{Dead time: } T_d = 16/f_{osc} \text{ (s) (In more than } V_e = 5.0 \text{ V)}$$

$$T_{ONL} = \text{carrier cycle} \times 8\% \text{ (s) (Uniformity)}$$

When the motor is driven by a square wave, acceleration/deceleration is determined by voltage V_e . The motor accelerates/decelerates according to the On duty of T_{ONU} (see the diagram of output On duty on page 13).

Note: At startup, the motor is driven by a square wave when the Hall signals are 5 Hz or lower ($f_{osc} = 4 \text{ MHz}$) and the motor is rotating in the reverse direction as the TB6556F controls it (REV = High).

Operating Waveform When Driven by Sine-Wave PWM (CW/CCW = Low, OS = High)

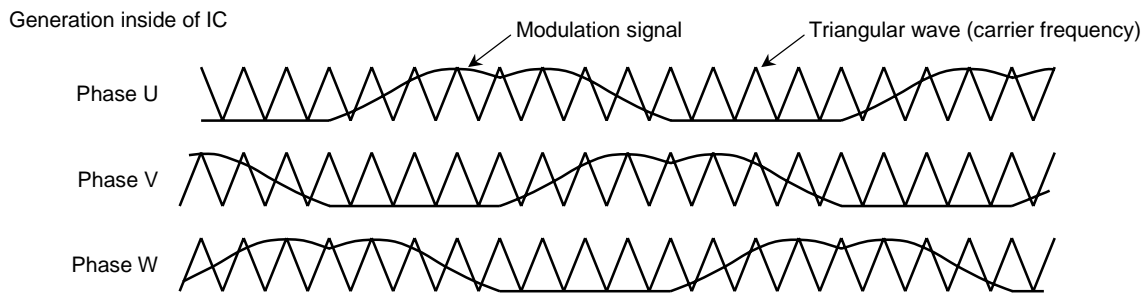

Output waveform

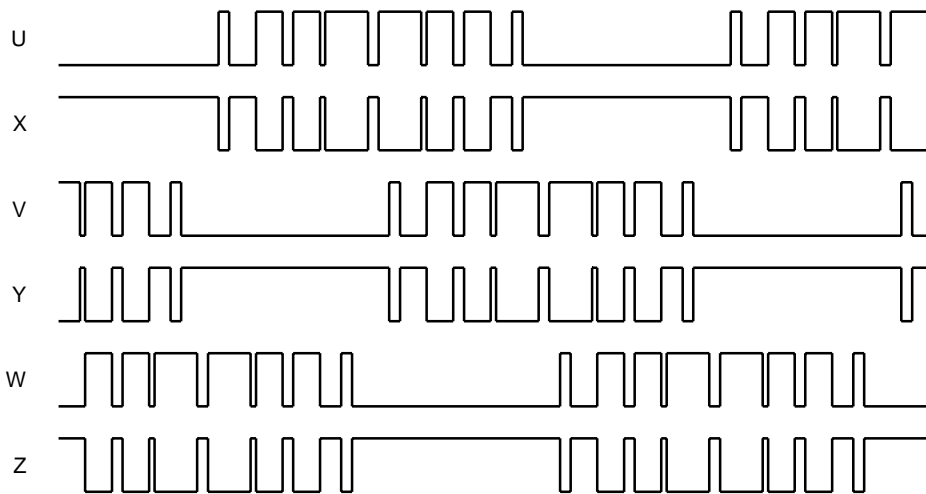

Inter-line voltage

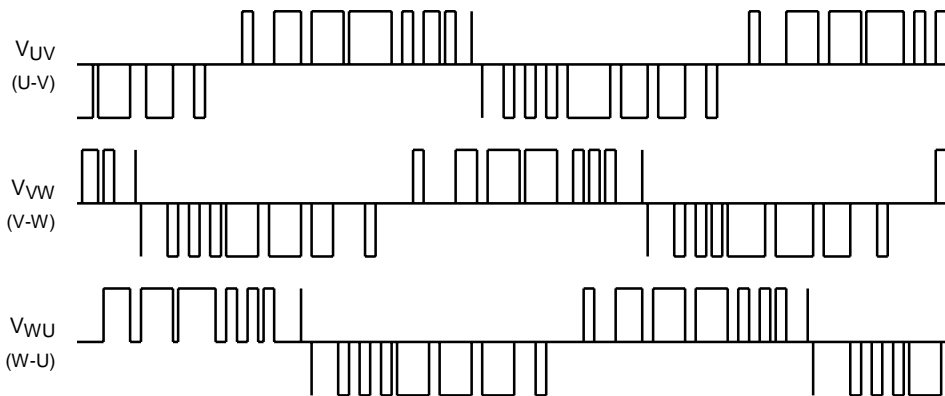

When the motor is driven by a sine wave, the motor is accelerated/decelerated according to the On duty of TONU when the amplitude of the modulation symbol changes by voltage V_e (see the diagram of output On duty on page 13).

$$\text{Triangular wave frequency} = \text{carrier frequency} = f_{osc}/252 \text{ (Hz)}$$

Note: At startup, the motor is driven by a sine wave when the Hall signals are 5 Hz or higher ($f_{osc} = 4 \text{ MHz}$) and the motor is rotating in the same direction as the TB6556F controls it (REV = Low).

Example of Application Circuit

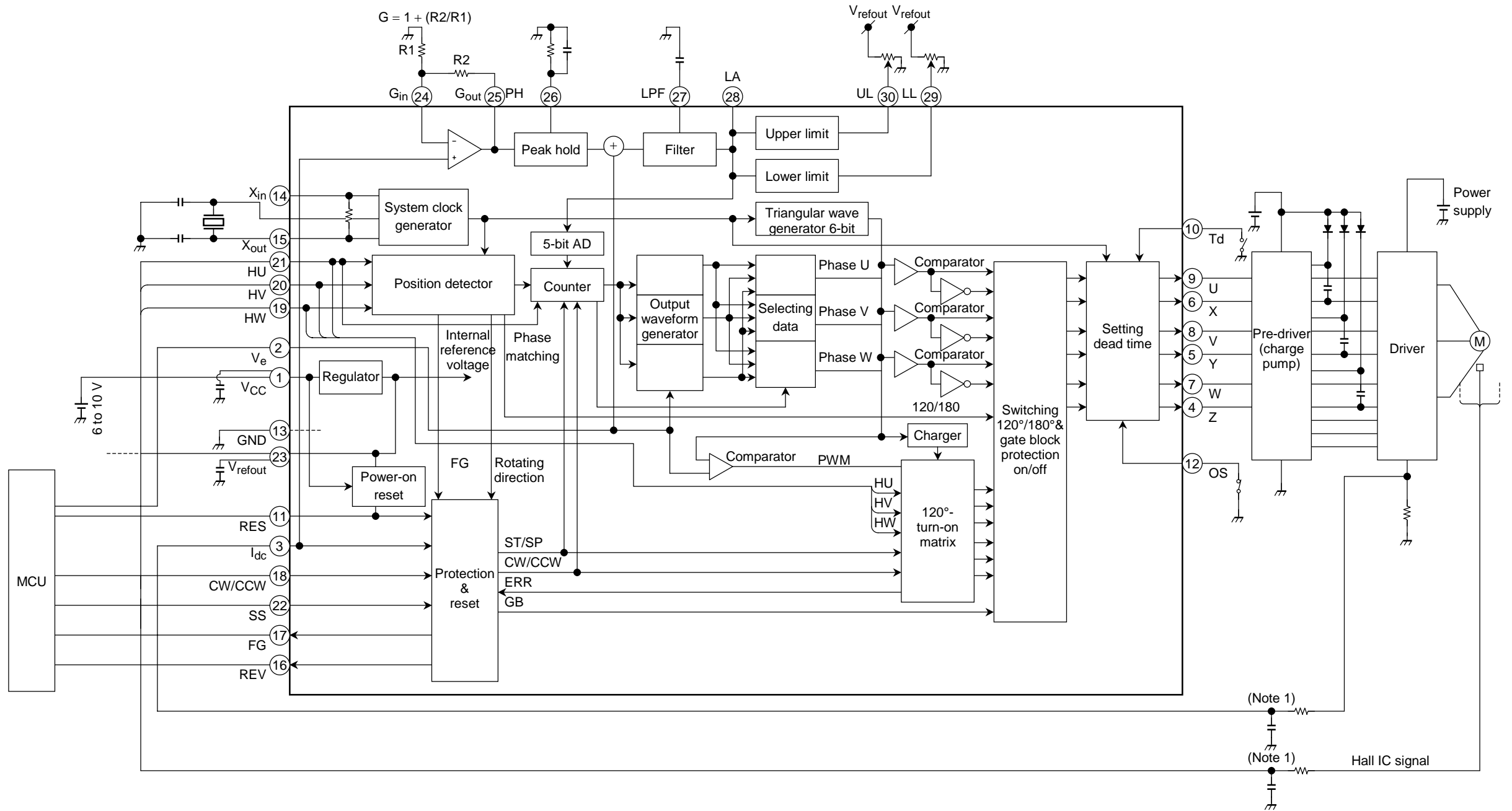

Note 1: For preventing the IC from misoperation caused by noise for example connect to ground as required.

Note 2: Connect GND to signal ground on an application circuit.

Note 3: A short circuit between the outputs, or between output and supply or ground may damage the device. Peripheral parts may also be damaged by overvoltage and overcurrent. Design the output lines, V_{CC} and GND lines so that short circuits do not occur.

Also be careful not to insert the IC in the wrong direction because this could destroy the IC.

Package Dimensions

SSOP30-P-375-1.00

Unit : mm

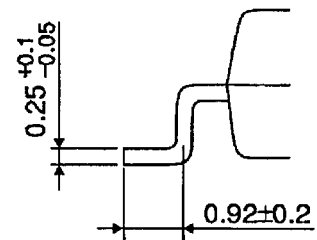
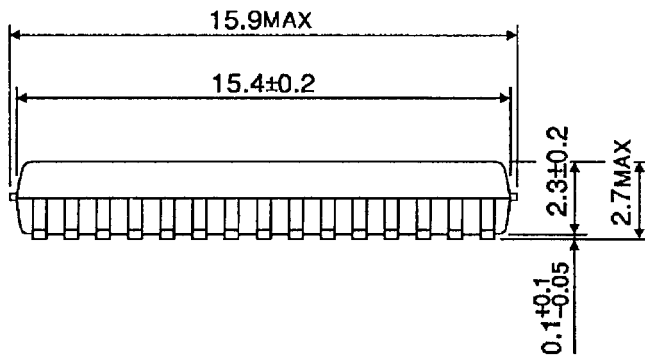
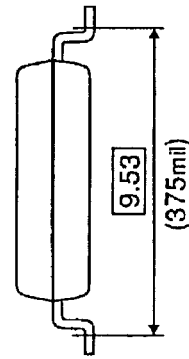
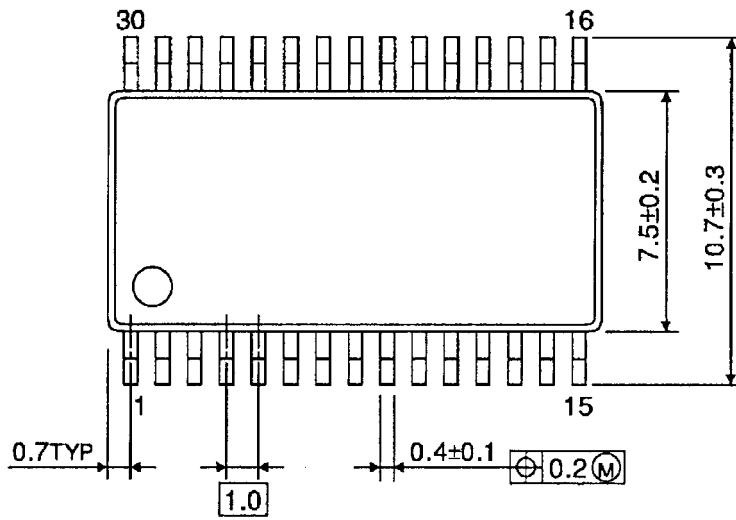

Weight: 0.63 g (typ.)

RESTRICTIONS ON PRODUCT USE

030619EBA

- The information contained herein is subject to change without notice.
- The information contained herein is presented only as a guide for the applications of our products. No responsibility is assumed by TOSHIBA for any infringements of patents or other rights of the third parties which may result from its use. No license is granted by implication or otherwise under any patent or patent rights of TOSHIBA or others.
- TOSHIBA is continually working to improve the quality and reliability of its products. Nevertheless, semiconductor devices in general can malfunction or fail due to their inherent electrical sensitivity and vulnerability to physical stress. It is the responsibility of the buyer, when utilizing TOSHIBA products, to comply with the standards of safety in making a safe design for the entire system, and to avoid situations in which a malfunction or failure of such TOSHIBA products could cause loss of human life, bodily injury or damage to property.
In developing your designs, please ensure that TOSHIBA products are used within specified operating ranges as set forth in the most recent TOSHIBA products specifications. Also, please keep in mind the precautions and conditions set forth in the "Handling Guide for Semiconductor Devices," or "TOSHIBA Semiconductor Reliability Handbook" etc..
- The TOSHIBA products listed in this document are intended for usage in general electronics applications (computer, personal equipment, office equipment, measuring equipment, industrial robotics, domestic appliances, etc.). These TOSHIBA products are neither intended nor warranted for usage in equipment that requires extraordinarily high quality and/or reliability or a malfunction or failure of which may cause loss of human life or bodily injury ("Unintended Usage"). Unintended Usage include atomic energy control instruments, airplane or spaceship instruments, transportation instruments, traffic signal instruments, combustion control instruments, medical instruments, all types of safety devices, etc.. Unintended Usage of TOSHIBA products listed in this document shall be made at the customer's own risk.
- The products described in this document are subject to the foreign exchange and foreign trade laws.
- TOSHIBA products should not be embedded to the downstream products which are prohibited to be produced and sold, under any law and regulations.