

CMOS 8-Bit Microcontroller

TMP88PS42N/F

The TMP88PS42 is a high-speed, high-function 8-bit single-chip microcomputer incorporating 64-Kbyte one-time PROM. This microcomputer is pin compatible with the TMP88CS42, the mask ROM product. Once a program is written into its internal PROM, this microcomputer operates the same way as the TMP88CS42. By using an adapter socket, the TMP88PS42 can be programmed and verified with a general-purpose PROM programmer in the same way as for the TC571000D/AD.

Product No.	ROM	RAM	Package	Adapter Socket
TMP88PS42F	64 Kbytes	2 K + 128 bytes	P-QFP64-1420-1.00A	BM11200
TMP88PS42N			P-SDIP64-750-1.78	BM11199

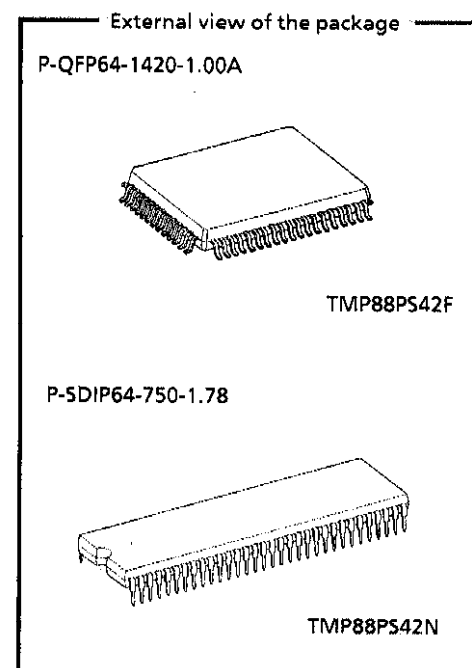

030519EBP1

- The information contained herein is subject to change without notice.
- The information contained herein is presented only as a guide for the applications of our products. No responsibility is assumed by TOSHIBA CORPORATION for any infringements of intellectual property or other rights of the third parties which may result from its use. No license is granted by implication or otherwise under any intellectual property or other rights of TOSHIBA CORPORATION or others.
- TOSHIBA is continually working to improve the quality and reliability of its products. Nevertheless, semiconductor devices in general can malfunction or fail due to their inherent electrical sensitivity and vulnerability to physical stress. It is the responsibility of the buyer, when utilizing TOSHIBA products, to comply with the standards of safety in making a safe design for the entire system, and to avoid situations in which a malfunction or failure of such TOSHIBA products could cause loss of human life, bodily injury or damage to property. In developing your designs, please ensure that TOSHIBA products are used within specified operating ranges as set forth in the most recent TOSHIBA products specifications. Also, please keep in mind the precautions and conditions set forth in the "Handling Guide for Semiconductor Devices," or "TOSHIBA Semiconductor Reliability Handbook" etc..
- The TOSHIBA products listed in this document are intended for usage in general electronics applications (computer, personal equipment, office equipment, measuring equipment, industrial robotics, domestic appliances, etc.). These TOSHIBA products are neither intended nor warranted for usage in equipment that requires extraordinarily high quality and/or reliability or a malfunction or failure of which may cause loss of human life or bodily injury ("Unintended Usage"). Unintended Usage include atomic energy control instruments, airplane or spaceship instruments, transportation instruments, traffic signal instruments, combustion control instruments, medical instruments, all types of safety devices, etc.. Unintended Usage of TOSHIBA products listed in this document shall be made at the customer's own risk.
- The products described in this document are subject to the foreign exchange and foreign trade laws.
- TOSHIBA products should not be embedded to the downstream products which are prohibited to be produced and sold, under any law and regulations.
- For a discussion of how the reliability of microcontrollers can be predicted, please refer to Section 1.3 of the chapter entitled Quality and Reliability Assurance/Handling Precautions.

Pin Assignment (Top View)

P-QFP64-1420-1.00A

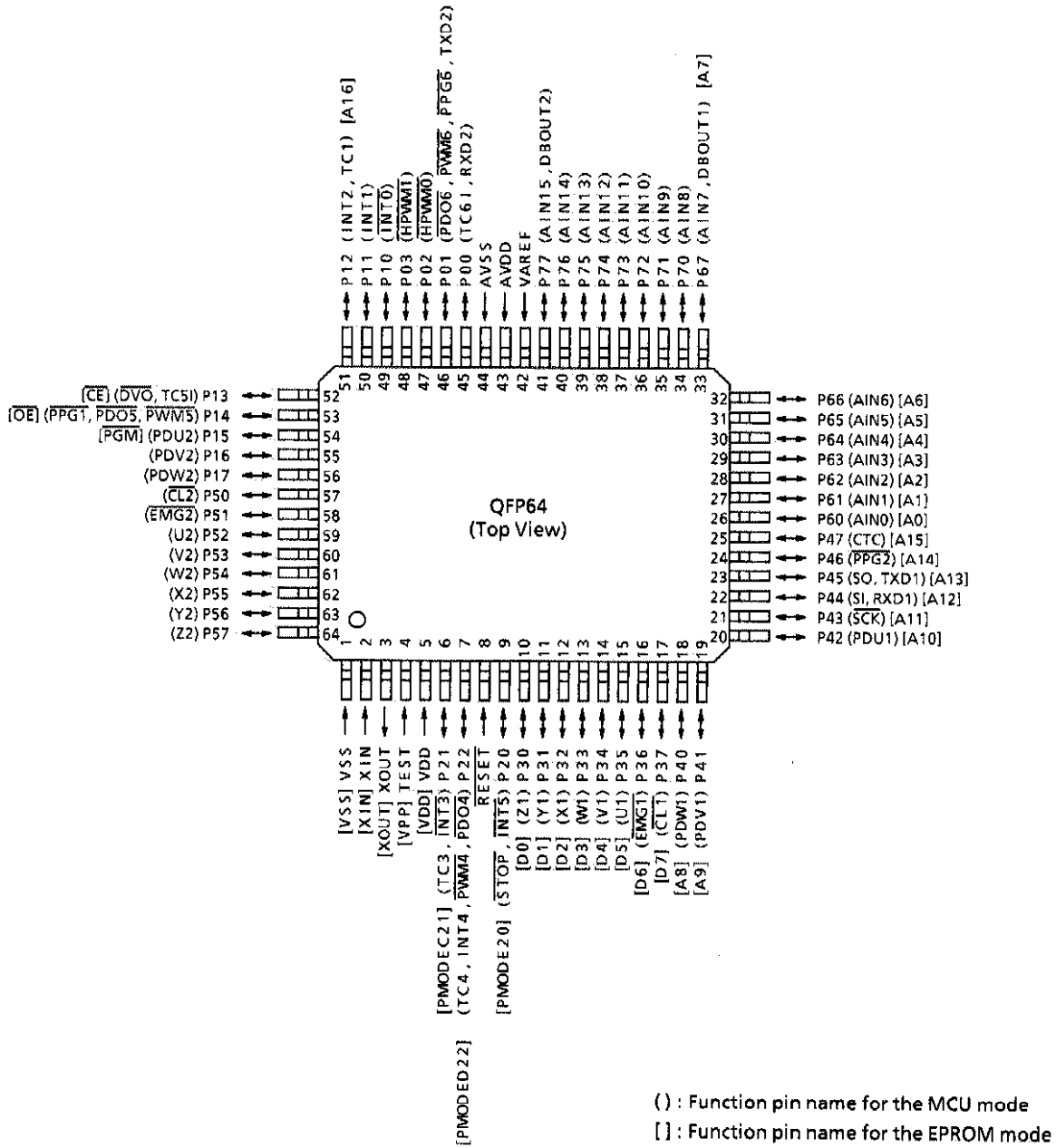

Pin Assignment (Top View)

P-SDIP64-750-1.78

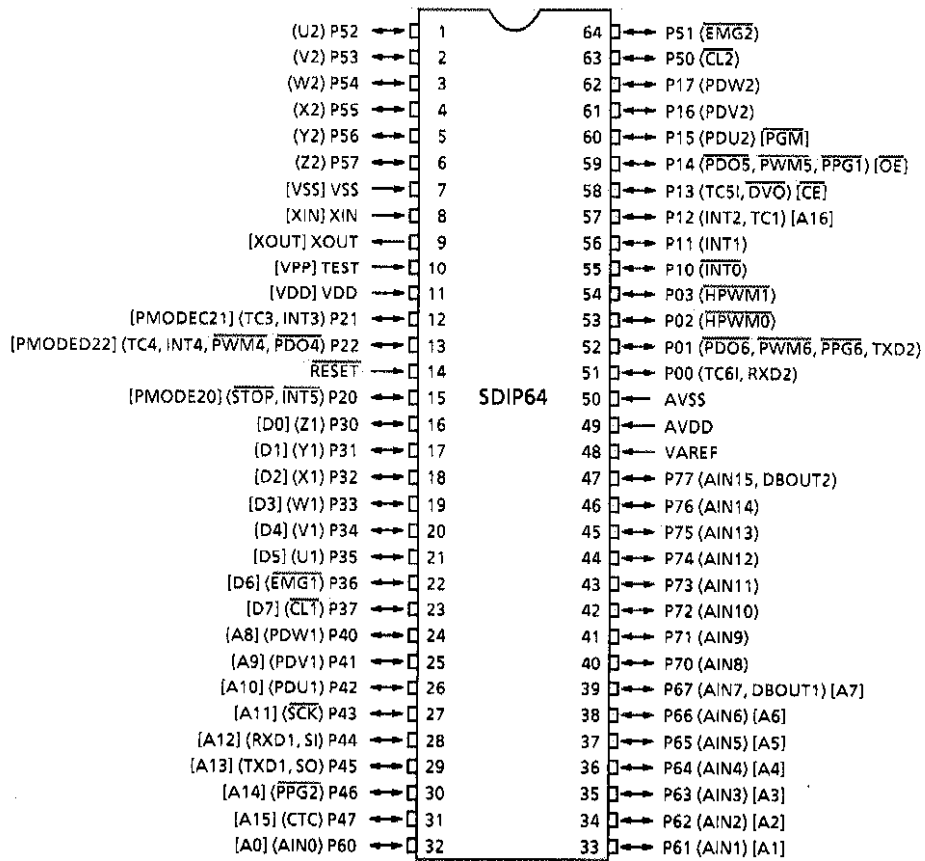

() : Function pin name for the MCU mode

[] : Function pin name for the EPROM mode

Pin Functions

The TMP88PS42 has MCU and PROM modes.

(1) MCU mode

Pin compatible with the TMP88CS42 (always makes sure the TEST pin is fixed low).

(2) PROM mode

Pin Name (during PROM Mode)	I/O	Functions	Pin Name (during MCU Mode)
A16	Input	Program memory address input	P12
A15 to A8			P47 to P40
A7 to A0			P67 to P60
D7 to D0	Input/output	Program memory data input/output	P37 to P30
\overline{CE}	Input	Chip enable signal input	P13
\overline{OE}		Output enable signal input	P14
\overline{PGM}		Program mode signal input	P15
VPP	Power supply	+ 12.75 V/5 V (Programming power supply)	TEST
VDD		+ 6.25 V/5 V	VDD
GND		0 V	VSS
P03 to P00	Input/output	Leave these pins open.	
P17 to P16			
P57 to P50			
P77 to P70			
P21		PROM mode setup pins. Fix these pins high.	
P11 to P10		PROM mode setup pins. Fix these pins low.	
P22, P20			
\overline{RESET}		Attach a resonator (20 MHz) to these pins for self-oscillation.	
XIN			
XOUT	Power supply	5 V	
AVDD		0 V (GND)	
VAREF			
VASS			

Functional Description

The TMP88PS42 is a one-time PROM version of the TMP88CS42 with its internal mask ROM replaced with one-time PROM. All other configurations and functions are the same as those of the TMP88CS42. (TMP88CS42 RAM size is 2 K + 128 bytes.) Immediately after a reset, the TMP88PS42 is in single-clock mode.

1. Operation Modes

The TMP88PS42 has MCU and PROM modes.

1.1 MCU Mode

The microcomputer is placed in MCU mode by fixing the TEST and VPP pins low.

In this mode, the microcomputer operates the same way as the TMP88CS42 (because the TEST and VPP pins do not have internal pulldown resistors, they cannot be left open while in use).

1.1.1 Program Memory

The TMP88PS42 contains a 64-Kbyte one-time PROM (located at addresses 04000 to 13EFF_H or addresses FFF00 to FFFFF_H during MCU mode and addresses 00000 to 0FFFF_H during PROM mode). When using this microcomputer for the purpose of evaluating the system constructed with the TMP88CS42, write a program into the program storage area shown in Figure 1-1.

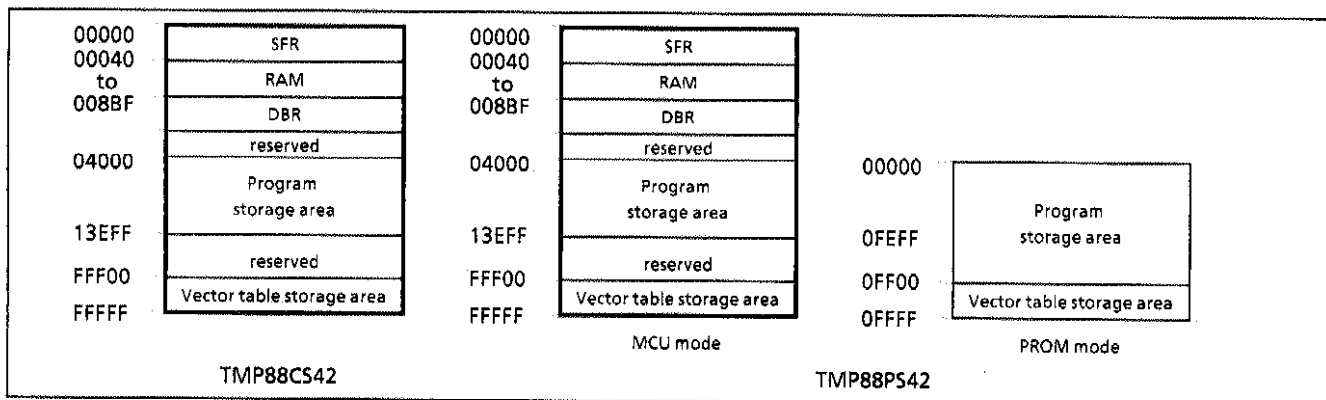

Figure 1-1. Program Storage Area

Note: Fill the unused area with data FF_H, or set up the general-purpose PROM programmer so that only the program storage area will be accessed.

1.1.2 Data Memory

The TMP88PS42 contains 2 K + 128-byte data memory (static RAM).

1.1.3 Input/Output Circuits of the Pins

(1) Control pins

The control pins are the same as those of the TMP88CS42, except that the TEST pin does not have an internal pulldown resistor.

(2) Input/output ports

The input/output circuits of the TMP88PS42 input/output ports are the same as those of the TMP88CS42.

1.2 PROM Mode

The microcomputer is placed in PROM mode by setting the $\overline{\text{RESET}}$ pin, ports P11 and P10, and ports P22 to P20 as shown in Figure 1-2. In this mode, a program can be written into the microcomputer and verified for by using a general-purpose PROM programmer.

Note: The microcomputer can be programmed in fast programming mode (because settings vary with each PROM programmer used, consult the user's manual of your PROM programmer). Because the TMP88PS42 does not have the electric signature function, set the ROM type of your PROM programmer to be the TC57100D/AD or equivalent.

When using one of the adapter sockets supported by Toshiba, set the switch to the N position.

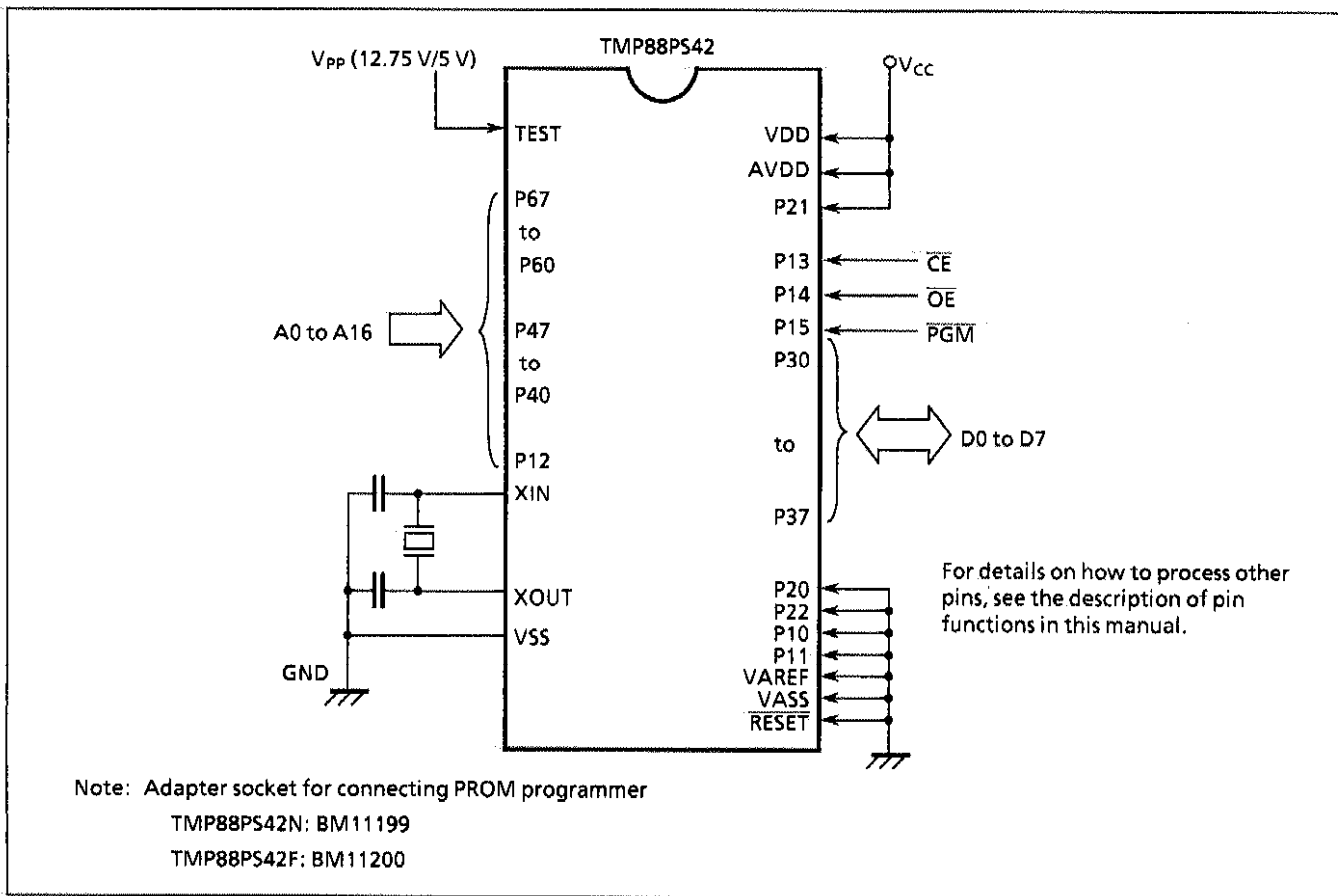

Figure 1-2. Setting Up PROM Mode

1.2.1 Programming Flowchart (Fast programming mode)

Fast programming mode is entered into by applying a programming voltage of $V_{pp} = 12.75\text{ V}$ while $V_{CC} = 6.25\text{ V}$. After setting the valid address and input data, apply a 0.1 ms programming (one-shot) pulse to the $\overline{\text{PGM}}$ input, and the data is written into the PROM. Verify whether data has been written into the PROM and if not written into correctly, apply a 0.1 ms programming pulse again. Repeat this (up to 25 times) until data is written into correctly. When data has been written to the set address correctly, proceed to write the next address and input data. When all data has been programmed in this way, set $V_{CC} = V_{PP} = 5\text{ V}$ and verify all addresses.

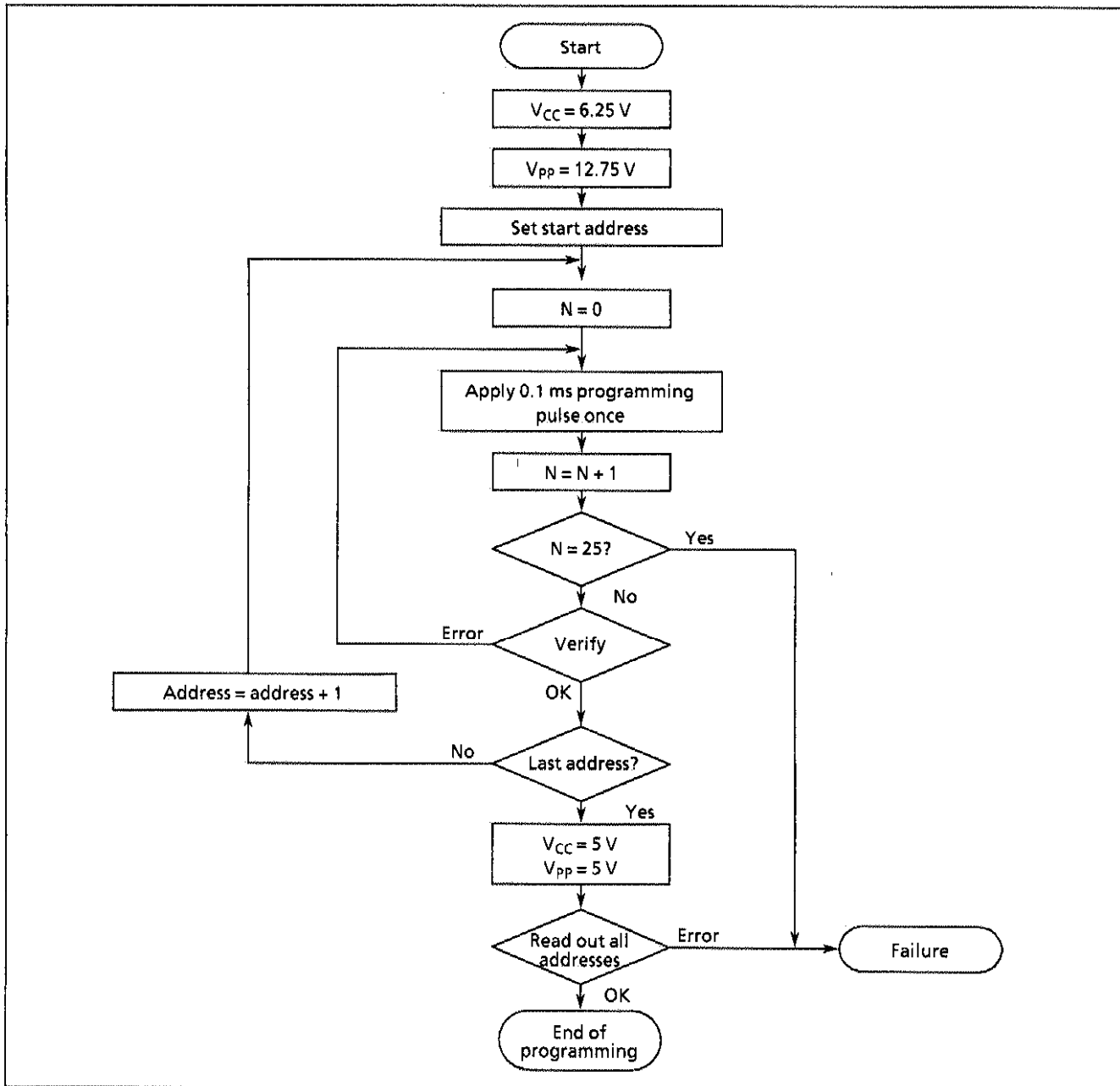

Figure 1-3. Programming Flowchart

1.2.2 Method of Programming Using a General-purpose PROM Programmer and Toshiba Adapter Socket

(1) Preparing the adapter

BM11199: Provided for use with the TMP88PS42N.

BM11200: Provided for use with the TMP88PS42F.

(2) Setting up the adapter

Set the switch (SW1) to the N position.

(3) Setting up the PROM programmer

i) Set the PROM type for the TC571000D/AD.

Programming voltage: 12.75 V (fast programming mode)

ii) Transfer data (or copy) (Note 1).

The EPROM of this microcomputer exists in an area at addresses 00000 to 0FFFF_H. Therefore, data must be transferred (copied) to the addresses at which the program can be written to in PROM mode. For the relationship between program storage areas in MCU and PROM modes, refer to Figure 1-1, "Program Storage Area."

iii) Set the write addresses (Note 1).

Start address: 00000_H

End address: 0FFFF_H

(4) Programming

Write data to the PROM and verify the programmed data following the PROM programmer operation procedure.

- Note 1: For details on how to set, consult the user's manual of your PROM programmer. Make sure the data set in unused address areas all are FF_H.
- Note 2: When setting the MCU into the adapter or the adapter into the PROM programmer, make sure the No. 1 pin positions on both sides are matched. If erroneously set in the opposite direction, the MCU, adapter, or PROM programmer may be damaged.
- Note 3: This microcomputer does not support electric signature mode. Therefore, if the PROM programmer is used in electric signature mode, the device may be damaged because a voltage of 12 V ± 0.5 V is applied to the No. 9 address pin (A9). Please do not use electric signature mode.

Electrical Characteristics

Absolute Maximum Ratings

 $(V_{SS} = 0V)$

Parameter	Symbol	Pin	Standard	Unit	Remark
Power Supply Voltage	V_{DD}		- 0.3 to 6.5	V	
Program Voltage	V_{PP}	TEST/VPP	- 0.3 to 13.0		
Input Voltage	V_{IN}		- 0.3 to $V_{DD} + 0.3$		
Output Voltage	V_{OUT}		- 0.3 to $V_{DD} + 0.3$		
Output Current	I_{OH}	P0, 1, 3, 4, 5, 6, 7	- 1.8	mA	
	I_{OL1}	P0, 1, 2, 6, 7	3.2		
	I_{OL2}	P3, P4, P5	30		
Mean Output Current	ΣI_{OUT1}	P0, 1, 2, 6, 7	60		Total of all ports except large-current ports
	ΣI_{OUT2}	P3	60		Total of 8 pins of large-current ports P30 to 7
	ΣI_{OUT3}	P4	60		Total of 8 pins of large-current ports P40 to 7
	ΣI_{OUT4}	P5	60		Total of 8 pins of large-current ports P50 to 7
Power Dissipation	PD	TMP88PS42N	600	mW	SDIP
		TMP88PS42F	350		QFP
Operating Temperature	T_{opr}		- 40 to 85	°C	
Soldering Temperature (time)	T_{sld}		260 (10 s)		
Storage Temperature	T_{stg}		- 55 to 125		

Note: The Absolute Maximum Ratings stipulate the standards, any parameter of which cannot be exceeded even in an instant. If the device is used under conditions exceeding the Absolute Maximum Ratings, it may break down or degrade, causing injury due to rupture or burning. Therefore, always make sure the Absolute Maximum Ratings will not be exceeded when designing your application equipment.

Recommended Operating Conditions

 $(V_{SS} = 0V, T_{opr} = -40 \text{ to } 85^\circ\text{C})$

Parameter	Symbol	Pin	Condition		Min	Max	Unit
			$f_c = 20 \text{ MHz}$	NORMAL/IDLE/STOP			
Power Supply Voltage	V_{DD}				4.5	5.5	V
High Level Input Voltage	V_{IH1}	Normal (P6, P7)	$V_{DD} \geq 4.5 \text{ V}$		$V_{DD} \times 0.70$	V_{DD}	
	V_{IH2}	Hysteresis (P0, P1, P2, P3, P4, P5, RESET)			$V_{DD} \times 0.75$		
Low Level Input Voltage	V_{IL1}	Normal (P6, P7)	$V_{DD} \geq 4.5 \text{ V}$		0	$V_{DD} \times 0.30$	
	V_{IL2}	Hysteresis (P0, P1, P2, P3, P4, P5, RESET)			$V_{DD} \times 0.25$		
Clock Frequency	f_c	XIN, XOUT	$V_{DD} = 4.5 \text{ V to } 5.5 \text{ V}$		8	20	MHz

Note: The Recommended Operating Conditions show the conditions under which we recommend the device be used in order for it to operate normally while maintaining its quality. If the device is used outside the range of Recommended Operating Conditions (power supply voltage, operating temperature range, or AC/DC rated values), it may operate erratically. Therefore, when designing your application equipment, always make sure its intended working conditions will not exceed the range of Recommended Operating Conditions.

DC Characteristics (V_{SS} = 0 V, Topr = -40 to 85°C)

Parameter	Symbol	Pin	Condition	Min	Typ.	Max	Unit
Input Current	I _{IN1}	TEST	V _{DD} = 5.5 V V _{IN} = 5.5 V/0 V	-	-	±2	μA
	I _{IN2}	Sink open drain, Tri-state					
	I _{IN3}	RESET, STOP					
Input Resistance	R _{IN}	RESET		90	220	510	kΩ
Output Leakage Current	I _{LO}	Sink open drain, Tri-state	V _{DD} = 5.5 V, V _{IN} = 5.5 V/0 V	-	-	±2	μA
High Level Output Voltage	V _{OH}	Tri-state port	V _{DD} = 4.5 V, I _{OH} = -0.7 mA	4.1	-	-	V
Low Level Output Current	I _{OL1}	P0, 1, 2, 6, 7	V _{DD} = 4.5 V, V _{OL} = 0.4 V	1.6	-	-	mA
	I _{OL2}	P3, P5, P4	V _{DD} = 4.5 V, V _{OL} = 1.0 V	-	20	-	
Power Supply Current	I _{DDO}		V _{DD} = 5.5 V, V _{IN} = 5.3 V/0.2 V f _c = 20 MHz	-	18	25	μA
	I _{DDL}			-	16	23	
	I _{DDH}			-	2	100	

AD Conversion Characteristics (Topr = -40 to 85°C)

Parameter	Symbol	Pin	Min	Typ.	Max		Unit
					8 bits	10 bits	
Analog Reference Voltage	V _{REF}	V _{SS} = 0 V, V _{DD} = AV _{DD}	V _{DD} - 1.0	-	V _{DD}		V
Analog Input Voltage Range	V _{AIN}		V _{ASS}	-	V _{AREF}		
Analog Reference Power Supply Current	I _{REF}	V _{DD} = AV _{DD} = V _{AREF} = 5.0 V V _{SS} = AV _{SS} = 0 V	-	0.5	1.0		mA
Nonlinearity Error		V _{DD} = 5 V, V _{SS} = 0 V AV _{DD} = V _{AREF} = 5 V AV _{SS} = 0 V	-	-	±1	±2	LSB
Zero Error			-	-	±1	±2	
Full Scale Error			-	-	±1	±2	
Overall Error			-	-	±2	±4	

AC Characteristics (V_{SS} = 0 V, V_{DD} = 4.5 to 5.5 V, Topr = -40 to 85°C)

Parameter	Symbol	Pin	Min	Typ.	Max	Unit
Machine Cycle Time	t _{cy}	During NORMAL mode	0.2	-	0.5	μs
		During IDLE mode				
High Level Clock Pulse Width	t _{WCH}	When operating with external clock (XIN input)	-	25	-	ns
Low Level Clock Pulse Width	t _{WCL}	f _c = 20 MHz				

Recommended Oscillation Conditions (V_{SS} = 0 V, V_{DD} = 4.5 to 5.5 V, Topr = - 40 to 85°C)

Parameter	Resonator	Oscillation Frequency	Recommended Resonator	Recommended Constant	
				C ₁	C ₂
High-frequency oscillation	Ceramic resonator	16 MHz	CSTLS16MOX51-B0 made by Murata Mfg. Co.	(5 pF)	(5 pF)
		20 MHz	CSTLS20MOX51-B0 made by Murata Mfg. Co.	(5 pF)	(5 pF)

(C₁, C₂ built-in type)

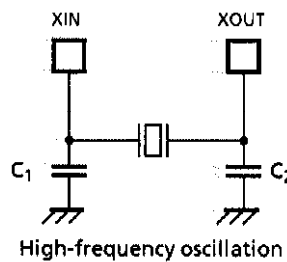

- Note 1:** When using the device in places exposed to high electric fields as in cathode-ray tubes, we recommend electrically shielding the package in order to maintain the device in normal working condition.
- Note 2:** These product numbers and the corresponding specifications are subject to change. For up-to-date information, please refer to the following URL:
<http://www.murata.co.jp/search/index.html>

DC/AC Characteristics (PROM mode)

($V_{SS} = 0\text{ V}$, $T_{opr} = 25 \pm 5^\circ\text{C}$)

(1) Read Operation

Parameter	Symbol	Condition	Min	Typ.	Max	Unit
Input High Voltage	V_{IH4}		$V_{CC} \times 0.7$	–	V_{CC}	V
Input Low Voltage	V_{IL4}		0	–	$V_{CC} \times 0.12$	
Power Supply Voltage	V_{CC}		4.75	5.0	5.25	
Program Power Supply Voltage	V_{PP}					
Address Access Time	t_{ACC}	$V_{CC} = 5.0 \pm 0.25\text{ V}$	–	$1.5t_{cyc} + 300$	–	ns

Note: $t_{cyc} = 200\text{ ns}$ at 20 MHz

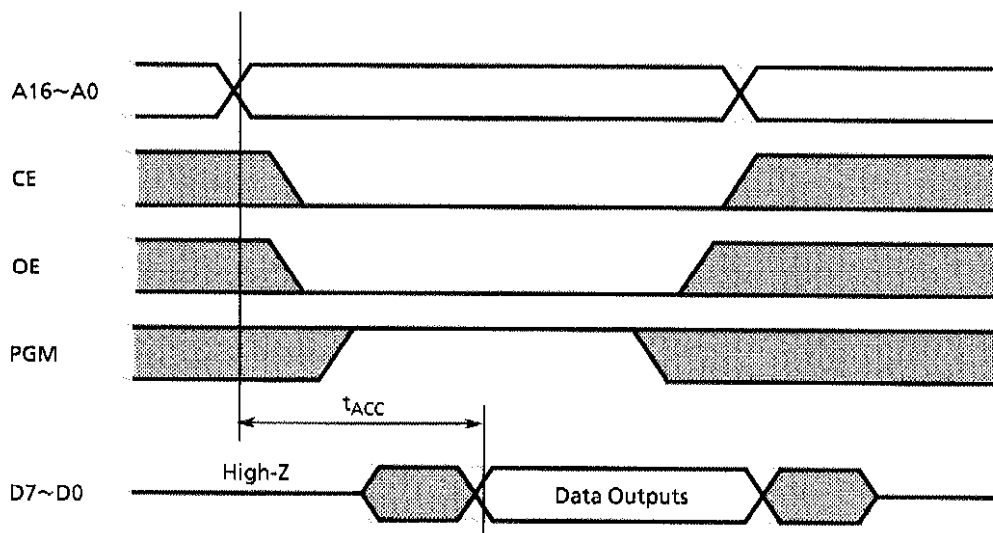

(2) High-Speed Programming Operation ($T_{opr} = 25 \pm 5^\circ\text{C}$)

Parameter	Symbol	Condition	Min	Typ.	Max	Unit
Input High Voltage	V_{IH4}		$V_{CC} \times 0.7$	–	V_{CC}	V
Input Low Voltage	V_{IL4}		0	–	$V_{CC} \times 0.12$	
Power Supply Voltage	V_{CC}		6.0	6.25	6.5	
Program Power Supply Voltage	V_{PP}		12.5	12.75	13.0	
Initial Program Pulse Width	t_{PW}	$V_{CC} = 6.0\text{ V}$	0.095	0.1	0.105	ms

High-speed program

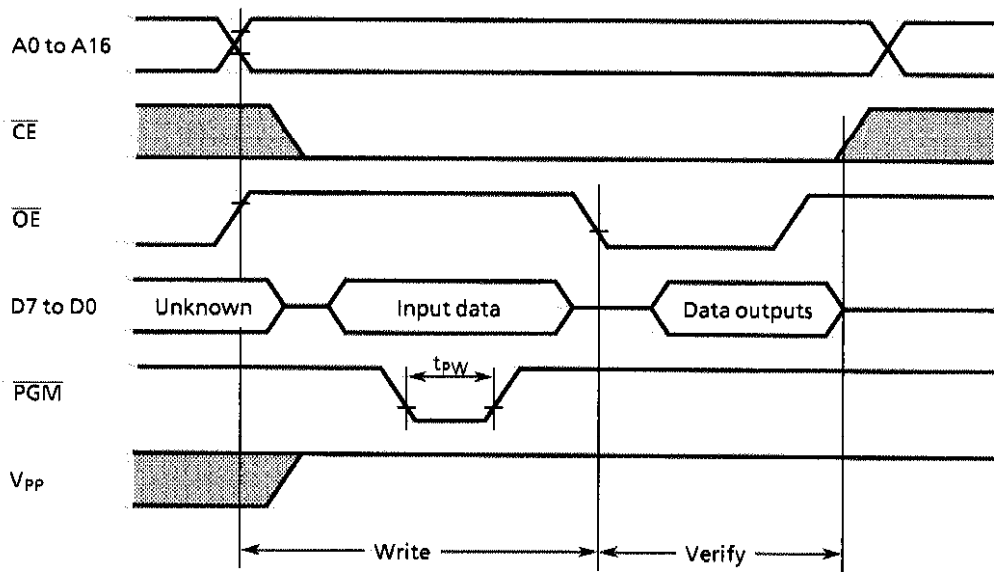

Note 1: The power supply of V_{PP} (12.75 V) must be set power-on at the same time or the later time for a power supply of V_{CC} and must be clear power-on at the same time or early time for a power supply of V_{CC} .

Note 2: The pulling up/down device on the condition of $V_{PP} = 12.75 \text{ V} \pm 0.25 \text{ V}$ causes a damage for the device. Do not pull up/down at programming.

Note 3: Use the recommended adapter and mode (See 1.2.2 (1) and 1.2.2 (3) i.).

Using other than the above condition may cause the trouble of the writing.

